

# Ball Valve

11.01

**DUNGS**<sup>®</sup>  
Combustion Controls



## Technical description

Rp 1/4 to Rp 2 ball valve, PN 5 as per DIN EN 331.

DN 25 to DN 200 ball valve, PN 16 as per DIN EN 13774, Part 1.

Rugged and very user-friendly design.

## Approvals

EC type testing certificate as per:

- EC-Gas Appliances Regulation
  - EC-Pressure Equipment Directive
- Approvals in other important gas consuming countries.

## Application

The ball valve is for manual shut-off and for releasing gases of families 1, 2, 3 and other neutral gaseous media.

Other media are air, water, light and domestic heating oils.

Each gas train in conventional design or as DUNGS GasMultiBloc<sup>®</sup> must be completed with a ball valve.

## Dimensions [mm]

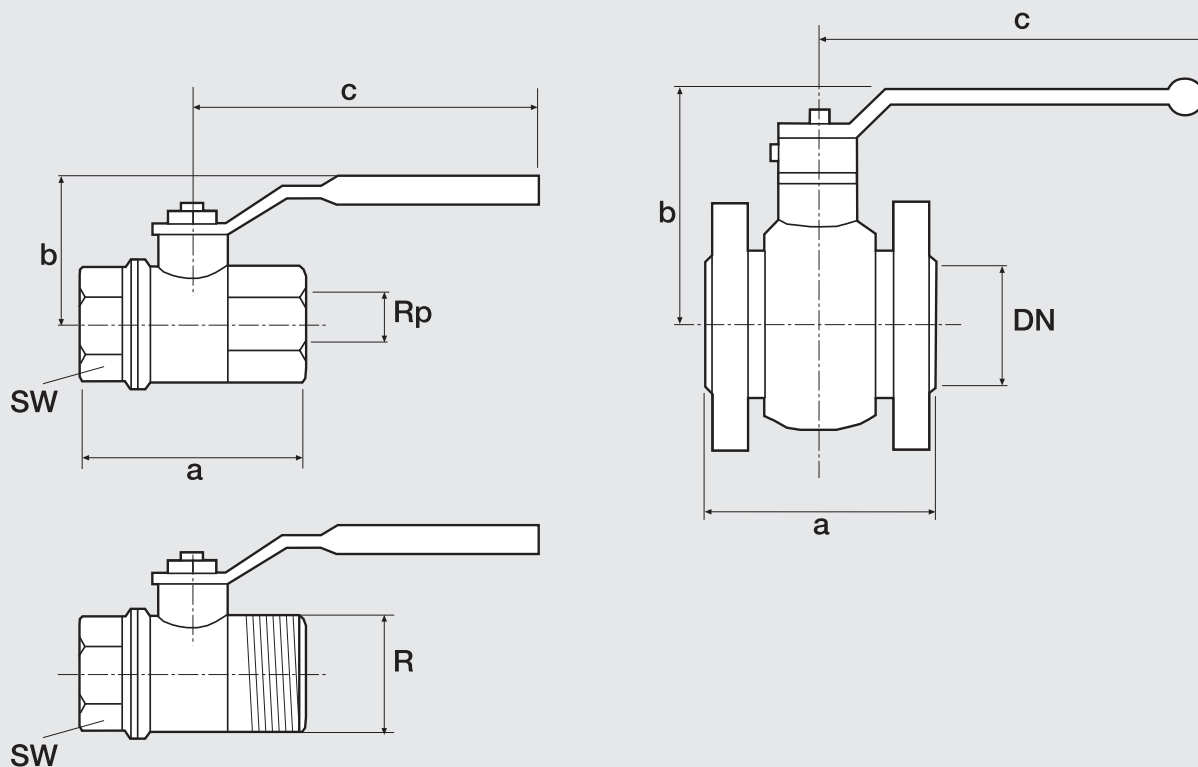

## Specifications

### Thread design KH 50...

Internal thread  
Rp 1/4 to Rp 2- DIN 2999  
External thread  
R 1/4 bis R 2 - ISO 7-1

Tube diameter  
DN 8 to DN 50

Operating pressure  
max. 5 bar

Temperature range  
-30 °C to +170 °C (in general)  
-20 °C to +60 °C (gas)

Housing  
brass, chrome-plated

Ball  
brass, chrome-plated

Seal  
PTFE

O rings  
Viton

Handle grip  
stainless steel with plastic coating

### Flange design KH 160...

Flange  
as per DIN EN 1092-2  
Overall length DN 25-150 as per DIN 3202-F4  
Overall length DN 200 as per DIN 3202-F5

Nominal diameters  
DN 25 to DN 200

Operating pressure  
max. 16 bar, Standard  
max. 4 bar, DN 25-100



Temperature range  
-20 °C to +60 °C (gas)

Housing  
spheroidal graphite iron casting (GGG40)

Ball  
hollow ball design (stainless steel)

Seal  
PTFE

O rings  
Viton, Perburan

Handle grip  
annealed cast iron/aluminium

free of nonferrous metals

Overview									
Article designation <sup>1)</sup>	Order no.	Max. operating pressure	Connection threads	Connection Rp/DN	Dimensions [mm]			SW <sup>2)</sup>	Weight [kg]
					a	b	c		
KH 5002 II	260 768	5 bar	Internal / internal	Rp 1/4	50	37	82	20	0.16
KH 5003 II	260 769	5 bar	Internal / internal	Rp 3/8	60	37	82	20	0.14
KH 5005 II	260 772	5 bar	Internal / internal	Rp 1/2	75	42	100	25	0.25
KH 5007 II	260 773	5 bar	Internal / internal	Rp 3/4	80	45	100	32	0.39
KH 5010 II	260 774	5 bar	Internal / internal	Rp 1	90	54	120	41	0.57
KH 5012 II	260 776	5 bar	Internal / internal	Rp 1 1/4	110	58	120	50	0.82
KH 5015 II	260 777	5 bar	Internal / internal	Rp 1 1/2	120	76	160	55	1.21
KH 5020 II	260 778	5 bar	Internal / internal	Rp 2	140	84	160	70	1.77
KH 5002 IA	260779	5 bar	Internal / external	Rp 1/4	56	37	82	21	0.16
KH 5003 IA	260 780	5 bar	Internal / external	Rp 3/8	57	37	82	21	0.16
KH 5005 IA	260 781	5 bar	Internal / external	Rp 1/2	72	42	100	26	0.25
KH 5007 IA	260 782	5 bar	Internal / external	Rp 3/4	83	45	100	32	0.40
KH 5010 IA	260 784	5 bar	Internal / external	Rp 1	91	54	120	41	0.59
KH 5012 IA	260 786	5 bar	Internal / external	Rp 1 1/4	108	58	120	50	0.86
KH 5015 IA	260 787	5 bar	Internal / external	Rp 1 1/2	116	76	160	54	1.22
KH 5020 IA	260 788	5 bar	Internal / external	Rp 2	133	84	160	69	1.79
KH 160 025	238 579	4 / 16 bar <sup>3)</sup>		DN 25	125	114	165		3.2
KH 160 032	238 580	4 / 16 bar <sup>3)</sup>		DN 32	130	125	165		4.7
KH 160 040	238 581	4 / 16 bar <sup>3)</sup>		DN 40	140	136	185		5.7
KH 160 050	238 582	4 / 16 bar <sup>3)</sup>		DN 50	150	143	185		7.6
KH 160 065	238 583	4 / 16 bar <sup>3)</sup>		DN 65	170	158	230		12.0
KH 160 080	238 584	4 / 16 bar <sup>3)</sup>		DN 80	180	186	360		15.5
KH 160 100	238 585	4 / 16 bar <sup>3)</sup>		DN 100	190	203	360		22.6
KH 160 125	238 586	16 bar		DN 125	200	223	360		24.5
KH 160 150	238 587	16 bar		DN 150	210	230	625		33.5
KH 160 200	096 818	16 bar		DN 200	400	316	715		91.0

<sup>1)</sup> KH = Ball valve <sup>2)</sup> SW = wrench width <sup>3)</sup> 4 bar @ HTB 650 °C

Subject to change without notice to reflect technical advances.

**Head Offices and Factory**  
**Karl Dungs GmbH & Co. KG**  
**Karl-Dungs-Platz 1**  
**D-73660 Urbach, Germany**  
**Telefon +49 (0)7181-804-0**  
**Telefax +49 (0)7181-804-166**

**Postal address**  
**Karl Dungs GmbH & Co. KG**  
**Postfach 12 29**  
**D-73602 Schorndorf, Germany**  
**e-mail [info@dungs.com](mailto:info@dungs.com)**  
**Internet [www.dungs.com](http://www.dungs.com)**