

**AUTOFLAME**<sup>®</sup>

Combustion Management Systems



# **MK8 EGA EVO MM82004/E Setup Guide**

Technical Manual

**04.12.2019**



AUTOFLAME ENGINEERING LTD  
Unit 1-2, Concorde Business Centre  
Airport Industrial Estate  
Wireless Road, Biggin Hill  
Kent TN16 3YN  
United Kingdom

Tel: +44 (0)1959 578 820  
Email: [technicalsupport@autoflame.com](mailto:technicalsupport@autoflame.com)  
Website: [www.autoflame.com](http://www.autoflame.com)

**Technical Manual**

**Mk8 EGA EVO Setup Guide**  
**Part No. MM82004/E**

**4 December 2019**

This manual and all the information contained herein is copyright of Autoflame Engineering Ltd. It may not be copied in the whole or part without the consent of the Managing Director.

Autoflame Engineering Ltd's policy is one of continuous improvement in both design and manufacture. We therefore reserve the right to amend specifications and/or data without prior notice. All details contained in this manual are correct at the time of going to print.

## **Important Notes**

A knowledge of combustion related procedures and commissioning is essential before embarking work on any of the M.M./E.G.A. systems. This is for safety reasons and effective use of the M.M./ E.G.A. system. Hands on training is required. For details on schedules and fees relating to group training courses and individual instruction, please contact the Autoflame Engineering Ltd. offices at the address listed on the front.

## **Short Form - General Terms and Conditions**

A full statement of our business terms and conditions are printed on the reverse of all invoices. A copy of these can be issued upon application, if requested in writing.

The System equipment and control concepts referred to in this Manual MUST be installed, commissioned and applied by personnel skilled in the various technical disciplines that are inherent to the Autoflame product range, i.e. combustion, electrical and control.

The sale of Autoflame's systems and equipment referred to in this Manual assume that the dealer, purchaser and installer has the necessary skills at his disposal. i.e. A high degree of combustion engineering experience, and a thorough understanding of the local electrical codes of practice concerning boilers, burners and their ancillary systems and equipment.

## **Autoflame's warranty from point of sale**

- Two years on all electronic systems and components.
- One year on all mechanical systems, components and sensors.

The warranty assumes that all equipment supplied will be used for the purpose that it was intended and in strict compliance with our technical recommendations.

Autoflame's warranty and guarantee is limited strictly to product build quality, and design. Excluded absolutely are any claims arising from misapplication, incorrect installation and/or incorrect commissioning.

# **CONTENTS**

<b>1</b>	<b>INSTALLATION AND WIRING</b>	<b>1</b>
1.1	Mk8 EGA	1
1.1.1	Inside View	2
1.2	Fixing Holes and Dimensions	3
1.3	Technical Specifications	4
1.4	Standards	4
1.5	Flying Lead Wiring	5
1.5.1	EGA Connections	5
1.5.2	Flying Leads	6
1.6	Installing Sampling Probe and EGA	7
1.6.1	Sampling Probe Dimensions	7
1.6.2	Sampling Probe – Internal Layout	9
1.6.3	Assembly of Dry Filter	10
1.6.4	Sampling Probe Installation	11
1.6.5	EGA Installation	13
1.6.6	Cable Specification	14
1.7	Wiring Schematics	15
1.7.1	Connection between EGA and Mk8 MM	15
1.7.2	Connection between EGA, MM and DTI	16
1.7.3	Connection between EGA and DTI	17
1.8	Ancillary Parts	18
1.8.1	Air Inlet Filter	18
1.8.2	External Particulate Filter	19
1.8.3	Chilled Environmental Enclosure	20
1.8.4	Pre-Heated Air Sensor	22
<b>2</b>	<b>COMMISSIONING EGA</b>	<b>23</b>
2.1	Operating Modes	23
2.1.1	EGA through MM	23
2.1.2	Standalone EGA	25
2.2	EGA Settings	26
2.2.1	Commission Mode Settings	29
2.2.2	Fuel Setup Settings	37
2.2.3	Analogue Setup Settings	43
2.3	Commissioning MM with EGA	50
2.4	Calibration Schedule	51
2.5	Resetting Data	53
2.5.1	Reset Cells to Factory Calibration	53
2.5.2	Reset Run Times	53
2.5.3	Reset Other Data	53
<b>3</b>	<b>SYSTEM CONFIGURATION</b>	<b>54</b>
3.1	Language	54

3.2	Set Clock.....	55
3.3	Online Changes .....	56
3.3.1	Settings .....	56
3.3.2	Fuel Setup.....	56
3.3.3	Calibration Schedule.....	56
3.4	Run Times.....	57
3.5	Diagnostics .....	58
3.6	System Log.....	59
3.7	Manual .....	60
3.8	Cell Information.....	61
3.8.1	O <sub>2</sub> Cell Characteristics.....	62
3.8.2	CO, NO, NO <sub>2</sub> and SO <sub>2</sub> Cell Characteristics.....	63
3.8.3	CO <sub>2</sub> Sensor .....	64
3.9	Calibrate Now .....	64
<b>4</b>	<b>EGA OPERATION.....</b>	<b>65</b>
4.1	Sampling Screen Icons.....	65
4.1.1	Temperature .....	66
4.1.2	Emissions.....	67
4.1.3	Pressure.....	68
4.1.4	Fuel Flow .....	69
4.1.5	Faults .....	70
4.2	EGA Overview .....	71
4.2.1	Features and Benefits.....	71
4.2.2	System Operation .....	71
4.2.3	Overview of 3-Parameter Trim.....	72
4.3	EGA Trim Function .....	73
4.3.1	Trim Operation.....	73
4.3.2	Importance of Measuring 3-Parameters .....	74
4.3.3	Trim Correction Calculation .....	75
4.3.4	Trim Timing Operation .....	77
4.3.5	Channel 5 Trim (Mk8 MM Only).....	78
4.3.6	Trim Delay.....	78
4.4	Combustion Efficiency Calculations .....	79
4.5	Combustion Limits .....	80
4.5.1	O <sub>2</sub> Combustion Limits .....	81
4.5.2	NO Combustion Limits.....	82
4.5.3	CO Combustion Limits.....	83
4.5.4	Temperature Limits .....	84
4.6	Emission Gases Data Logging Units.....	85
4.7	Downloading EGA Long Term Logs .....	85
<b>5</b>	<b>REMOTE MONITORING.....</b>	<b>87</b>
5.1	Overview.....	87
5.2	Wiring.....	87

5.3	Direct Modbus Settings.....	88
5.4	Modbus Addresses .....	88
<b>6</b>	<b>SERVICING AND TROUBLESHOOTING .....</b>	<b>90</b>
6.1	Servicing .....	90
6.1.1	Sampling Probe Maintenance.....	90
6.1.2	Servicing EGA Sampling Probe.....	91
6.2	Shipping .....	92
6.3	Fault Codes.....	93
6.3.1	General Troubleshooting .....	95
6.3.2	Faults on MM .....	95

# 1 INSTALLATION AND WIRING

## 1.1 Mk8 EGA



1.1.1 Inside View

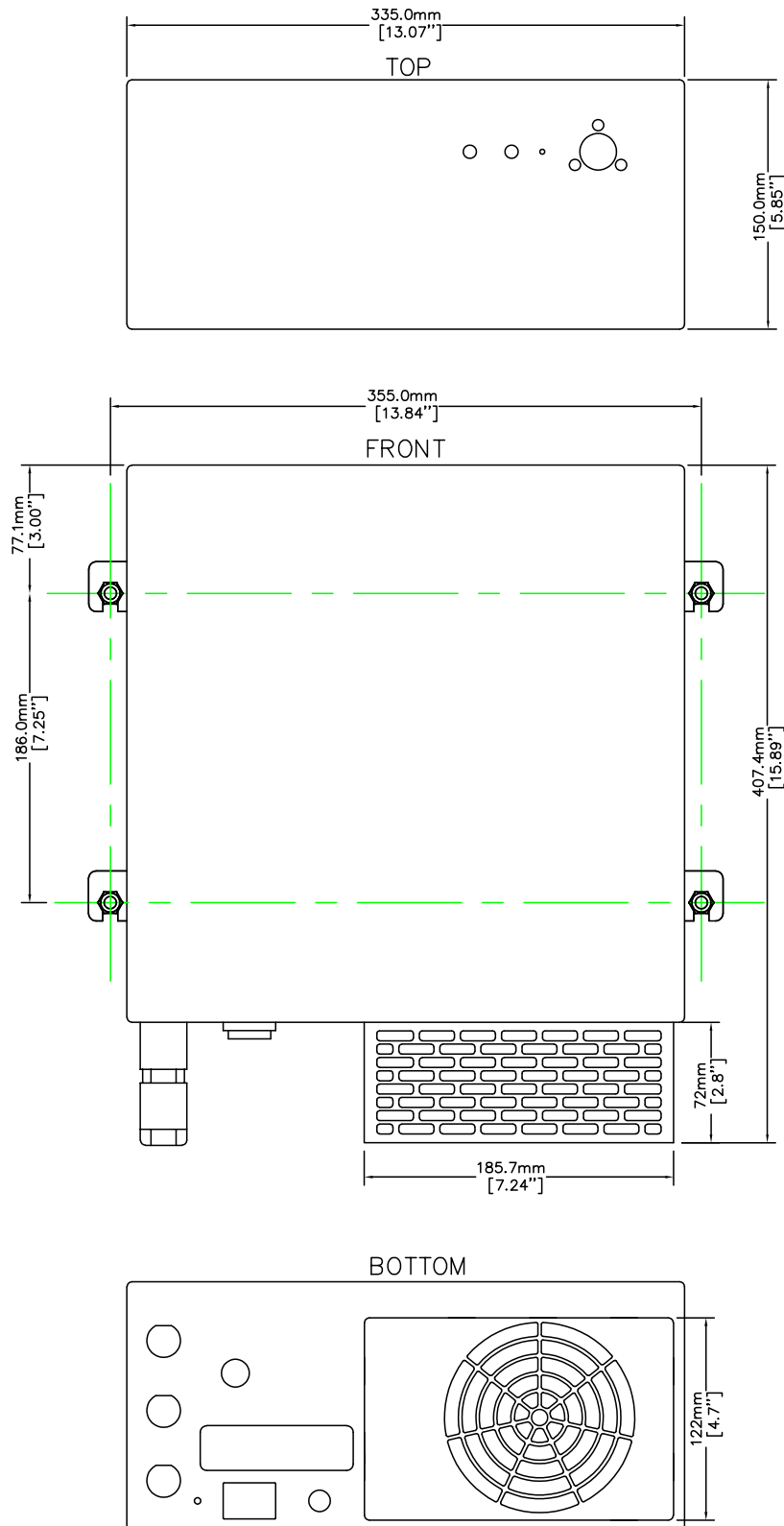

Figure 1.1.1.i Inside view of the EGA

1. Dry filter
2. Chiller block
3. Pinch valve
4. Drain solenoid
5. NO<sub>2</sub> cell (optional)
6. SO<sub>2</sub> cell (optional)
7. NO cell
8. O<sub>2</sub> cell
9. CO cell
10. CO<sub>2</sub> cell
11. Battery
12. Pump
13. Fan



## 1.2 Fixing Holes and Dimensions



100mm CLEARANCE IN THE TOP TO INSERT SAMPLING TUBE  
 100mm CLEARANCE IN THE RIGHT SIDE TO INSERT KEY  
 200mm CLEARANCE IN THE BOTTOM

### 1.3 Technical Specifications

Electrical Supply	230/110V (minimum 100V, maximum 240V) 50/60 Hz
Power Rating	160W
Max Power Consumption	225W
Fuse Rating	4A
Environmental Rating	IP20, NEMA 1
Internal Temperature	5 – 40°C (40 – 104°F)
K Type Thermocouple	0 – 400°C (32 – 752°F)
Sampling Tubing Environment Temperature	Maximum 60°C (140°F)
Pump Flow	600ml/min
Heating Sampling Line	Requires separate power supply. Power consumption will depend on application and length. Fuse rating on EGA for HSL is 20A.

### 1.4 Standards

The Mk8 EGA EVO conforms to the following legislations, standards and technical specifications:

- Low Voltage Directive: 2014/35/EU
- EMC Directive: 2014/30/EU
- Safety requirements for electrical equipment for measurement standard: BS EN 61010-1:2010
- Industrial, scientific and medical equipment standard: BS EN 55011:2016+A1:2017
- Electromagnetic compatibility (EMC) standards: BS EN 61000-4-2:2009, BS EN 61000-4-3:2006 +A1:2008 +A2:2010, BS EN 61000-4-4:2012, BS EN 61000-4-5:2014, BS EN 61000-4-6:2014, BS EN 61000-4-8:2010, BS EN 61000-3-2:2014, BS EN 61000-3-3:2013
- Canadian Standard for Temperature-Indicating and –Regulating Equipment: CSA C22.2
- US Standard for Limit Controls: UL 353
- US Combustion Safeguards and Flame Sensing Systems: FM 7610 1997
- US Low Water Level Limit Controls for Boilers: FM 7710 2003

The Mk8 EGA EVO is Manufactured and calibrated in compliance with the requirements of ISO 9001:2015 Quality Management System.

## 1.5 Flying Lead Wiring

### 1.5.1 EGA Connections



1. Pre-heated air sensor connection
2. Exhaust temperature thermocouple connection
3. Sampling line connection

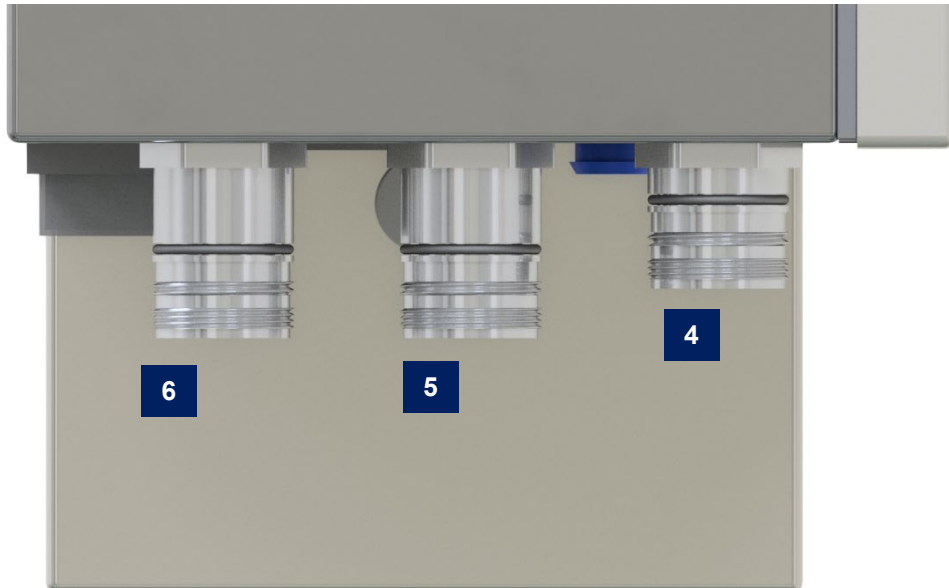

4. Mains flying leading connection
5. Data flying leading connection
6. Auxiliary flying lead connection

### 1.5.2 Flying Leads

Mains Flying Lead	Pin	Description
	1	Live
	2	Live for HSL*
	3	Earth for HSL
	4	Neutral for HSL
	5	Neutral
	6	Earth

\*Note: If a Heated Sample Line (HSL) is fitted, then a separate power supply is required.

Figure 1.5.2.i Mains  
(Insert Pin Mating View)

Data Flying Lead	Pin	Description
	1	Channel 1 4-20mA Output (+)
	2	Channel 2 4-20mA Output (+)
	3	Channel 3 4-20mA Output (+)
	4	Channel 4 4-20mA Output (+)
	5	Channel 5 4-20mA Output (+)
	6	Channel 6 4-20mA Output (+)
	7	Common for 4-20mA Outputs (-)
	8	Fuel 1 Select Input
	9	Fuel 2 Select Input
	10	Fuel 3 Select Input
	11	Fuel 4 Select Input
	12	Common for Fuel Select Input
	13	MM Comms (-)
	14	MM Comms (+)
	15	DTI Comms (-)
	16	DTI Comms (+)
	17	Common for Fuel Flow 4-20mA Input (-)
	18	Fuel Flow 4-20mA Input (+)
	19	Unused

\*Note: For standalone mode, a fuel select must be connected to pin 12 Common for Fuel Select Input.

Figure 1.5.2.ii Data  
(Insert Pin Mating View)

Auxiliary Flying Lead	Pin	Description
	1	External Drain (0V)*
	2	Unused
	3	Unused
	4	Unused
	5	External Drain (24V)
	6	Unused

\*Note: If an external particulate filter is fitted, then the 24V DC power supply required for the external drain, comes from the EGA.

Figure 1.5.2.iii Auxiliary  
(Insert Pin Mating View)

## 1.6 Installing Sampling Probe and EGA

The sampling probe must be purchased separately to the EGA and is supplied with the sampling tube for the exhaust gases and the thermocouple. The sampling tube and thermocouple is available in the below standard lengths, however if a different length is required, please contact Autoflame.

Sampling Probe	Sampling Tube and Thermocouple Length
MM10033	3m (10ft)
MM10033/5	5m (16ft)
MM10033/10	10m (33ft)

The EGA should be checked before installing it on site. It is advisory that EGA remains upright during any tests and checks. Thereafter the E.G.A should be turned off for a period (couple of hours), and turned back on again to drain out any excess moisture remaining in the EGA.

### 1.6.1 Sampling Probe Dimensions



1. Internal filter
2. Set screw 2mm (5/64")
3. Threaded probe socket 1.5" BSP/ NPT
4. Exhaust temperature thermocouple slot
5. Set screw 2mm (5/64")
6. Sampling line hole

Figure 1.6.1.i Sampling Probe Assembly

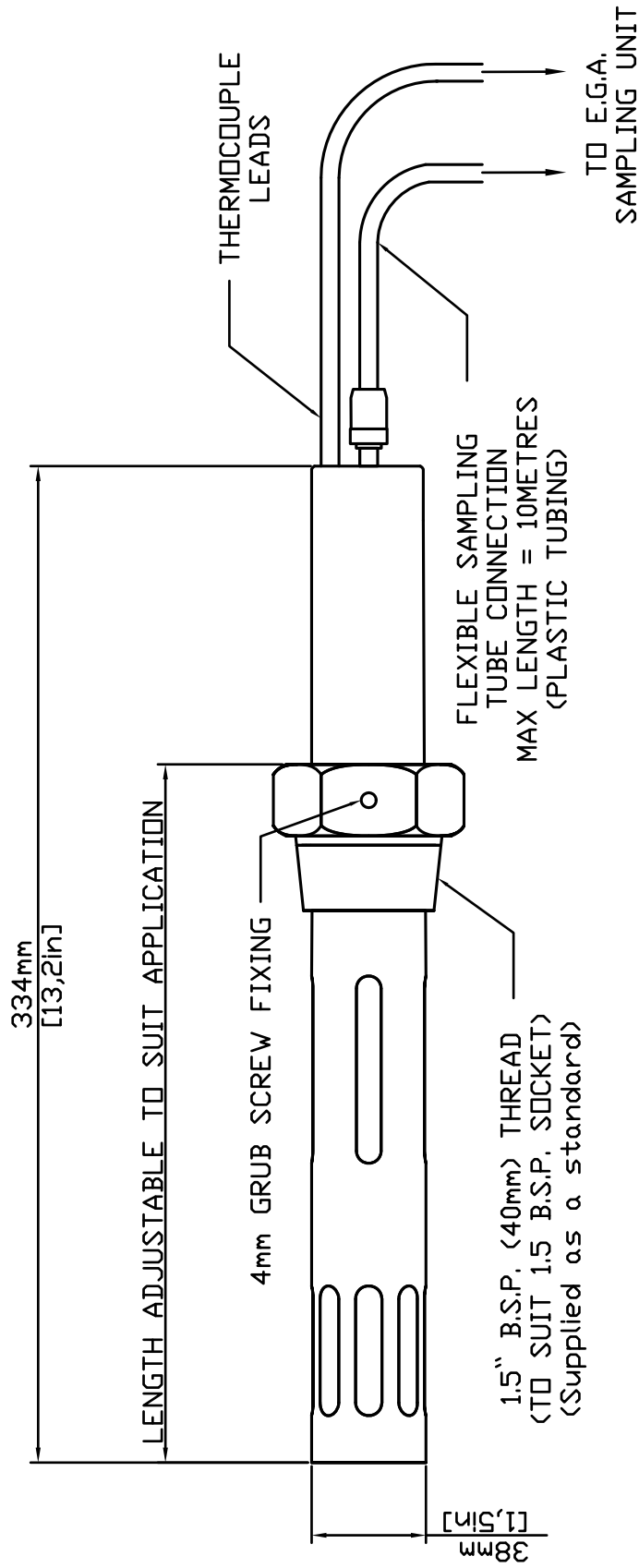

Drawing No. 7978

Figure 1.6.1.ii Sampling Probe Dimensions

### 1.6.2 Sampling Probe – Internal Layout

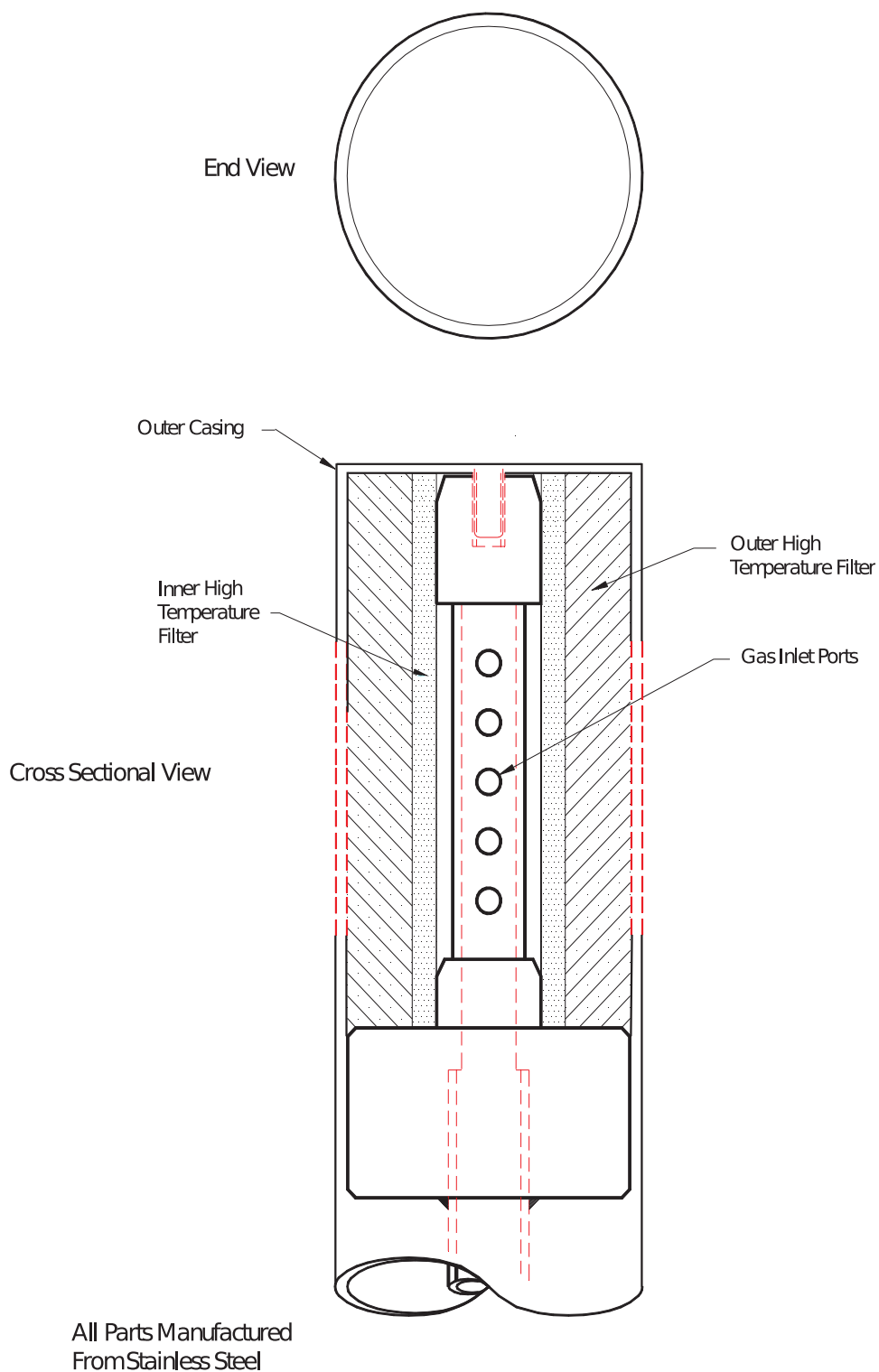
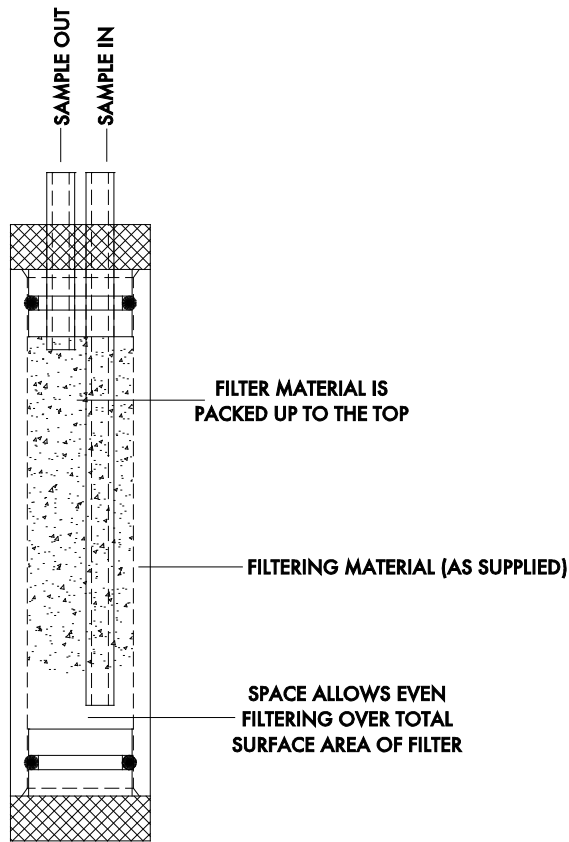

Figure 1.6.2.i Sampling Probe Internal Layout

### 1.6.3 Assembly of Dry Filter

If pump faults are occurring on the EGA it is advised to check the dry filter in the EGA and check for any blockages and make sure that the filter material has not become saturated.



**N.B. FREE SPACE MUST BE LEFT AT BOTTOM TO STOP ANY PREMATURE BLOCKAGE  
THE SAMPLE IN & OUT PIPES MUST BE CONNECTED CORRECTLY OR BLOCKAGE  
WILL OCCUR WITHIN A FEW HOURS.**

This filter is specifically used as a dry filter to remove and dust particulate before the dry gas passed into the cells. The filter is carefully packed as a complete replacement part and should be repacked or the filter material changed in the field, as the filter is critically calibrated for a specific pressure drop. The filter should always be dry, if any carryover of liquid or moisture is sent in the filter, please isolate the EGA and contact Autoflame Technical Support.



### 1.6.4 Sampling Probe Installation

The sampling probe must be installed as per the below guide to prevent any blockages in the line and incorrect operation.

1. Install a 1.5" BSP socket on the flue where the sampling probe is to be positioned.
  - a. If using the Autoflame draft control system, the sampling probe should be positioned after the stack damper and air pressure sensor.
  - b. If using a single EGA on a twin furnace, the sampling probe should be positioned after the individual flues are combined into one stack.
  - c. If an economiser is fitted to the flue, the sampling probe should be positioned before the economiser.
2. Mount the sampling probe at an angle of approximately 45° into the stack. This will allow any condensate in the sample to flow down to the EGA rather than causing blockages in the sampling line. A build-up of condensation in the EGA could result in a pump failure.
3. Mount the main body of the sampling probe as far in as possible; adjustment is made by loosening the grub screws in the flats of the 1.5" BSP bush supplied on the probe.

#### Notes

- Keep the thermocouple and blue sampling tube away from hot surfaces.
- The thermocouple should be positioned away from high voltage cabling.
- Ensure that the thermocouple and sampling tube run from the sampling probe to the EGA with no coils or loops.
- The sampling probe must be positioned without air leaks as this will result in incorrect readings on all cells.
- If the thermocouple is run in conduit from the sampling probe to the EGA, this must be earthed.

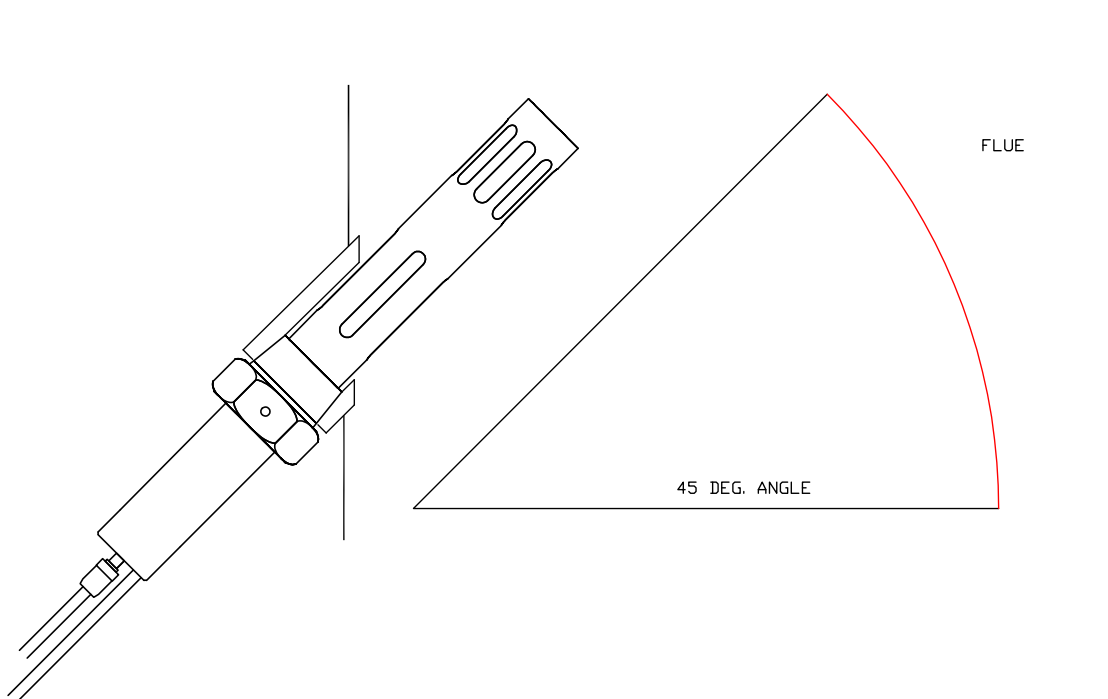

Figure 1.6.4.i EGA Probe 45° In Flue

Drawing No. 7978



*Figure 1.6.4.ii Incorrect installation of the sampling probe: a gully is formed in the sampling line will cause blockage*



*Figure 1.6.4.iii Correct installation of the sampling probe: the sample can flow down the sampling line with no restriction.*

### 1.6.5 EGA Installation

Once the sampling probe has been positioned and installed into the stack as per the guidelines in section 1.6.4, it can be connected to the EGA following the guidelines below.

1. Push the sampling line into the inlet tube.
2. Plug the thermocouple connector into the socket and tighten the screw.

#### Notes

- If the unit is started up for the first time, it may take some time for the chiller to cool down.
- To obtain optimum performance and reliability do not mount the unit in ambient temperatures above 40°C (104°F) or areas of direct heat radiation. If the ambient temperature is greater than 40°C (104°F), a chilled environmental enclosure is required, see section 1.8.3.
- For environments with high humidity, a chilled environmental enclosure is recommended to avoid corrosion on the electronics board, see section 1.8.3.
- If the EGA is placed in an enclosure or cabinet, to avoid the EGA being recalibrated on contaminated gases, ensure that the drain solenoid is taking in fresh air during calibration.
- Ensure that the air flow to the intake in the bottom of the EGA unit is not impeded and the air temperature is less than 40°C (104°F). If the burner air temperature is greater than 40°C (104°F), then a pre-heated air sensor is required, see section 1.8.4.
- Position the sample tube so that the sample slopes down to the EGA unit at all times. The EGA unit must always be mounted lower than the EGA probe. This helps drain excessive condensate from the flue gases, which may cause blockages in the sample tube.
- If extension tubing is attached to the drain solenoid, check that the end of the tubing is clear of any obstructions or contaminants. When the EGA performs an air calibration, the air is sucked into the EGA through the solenoid.
- Condensate in the EGA could also occur from the load demand not being so high at certain times, resulting in the back end temperature of the boiler being low and not warm enough to evaporate the condensation quick enough. This will cause a large build-up of moisture in the EGA, and so the time period between drains may need to be shorted in Commission Mode settings 43 and 44.
- Do not mount the units where excessive vibration occurs.
- The EGA should be positioned away from high voltage cabling.
- The EGA O<sub>2</sub>, CO, NO, SO<sub>2</sub> and NO<sub>2</sub> cells have a 6 month shelf-life. If ordering an EGA for project that will be installed later we would advise to purchase an EGA without these cells, and then purchase the cells when they are due to be installed. This EGA will come with the CO<sub>2</sub> cell only (patent no: MM72004/NC) as this can only be fitted at Autoflame office. We recommend that the cells are replaced 12-18months for gas firing from manufacturing date and 6-12 months for heavy oil firing applications.

### 1.6.6 Cable Specification

#### Low Voltage

The screened cable used for low voltage wiring from the EGA for the fuel flow 4-20mA input, and channels 1 to 6 4-20mA outputs must conform to the following specification:

16/0.2mm PVC insulated overall braid, screened, PVC sheathed.

- Sixteen wires per core
- Diameter of wires in each core 0.2mm
- Rated at 440V AC rms at 1600Hz
- DEF 61-12 current rating per core 2.5A
- Maximum operating temperature 70°C (158°F)
- Nominal conductor area 0.5sq mm per core
- Nominal insulation radial thickness on core 0.45mm
- Nominal conductor diameter per core 0.93mm
- Nominal core resistance at 20°C. 40.1Ω/1000m
- Nominal overall diameter per core 1.83mm
- Fill factor of braid screen 0.7
- Equivalent imperial conductor sizes 14/0.0076

Use the number of cores suitable for the application. A universal part numbering system appears to have been adopted for this type of cable as follows:

16-2-2C 2 Core  
16-2-3C 3 Core  
16-2-4C 4 Core  
16-2-6C 6 Core  
16-2-8C 8 Core

(5 Core not readily available)

**Note:** If using 4 Core cable and interference is detected, use 2 sets of 2 Core.

#### Data Cable

Data cable must be used for communication connections between MMs for sequencing applications as well as between MMs to EGAs, MMs to a DTI and DTI to BMS systems.

Communication cable should not exceed 1km.

Types of data cable that can be used:

- 1 Belden 9501 for 2-core shielded cable (1 twisted pair)
- 2 Belden 9502 for 4-core shielded cable (2 twisted pairs)
- 3 STC OS1P24

Samples are available upon request. Low voltage and data cable can be ordered directly from Autoflame Engineering, please contact Autoflame Sales.

## 1.7 Wiring Schematics

### 1.7.1 Connection between EGA and Mk8 MM

The data cable should be screened at the MM end and connected all the way to the EGA plug; the screen from the flying lead provided should be connected to the data cables that connect to the MM.

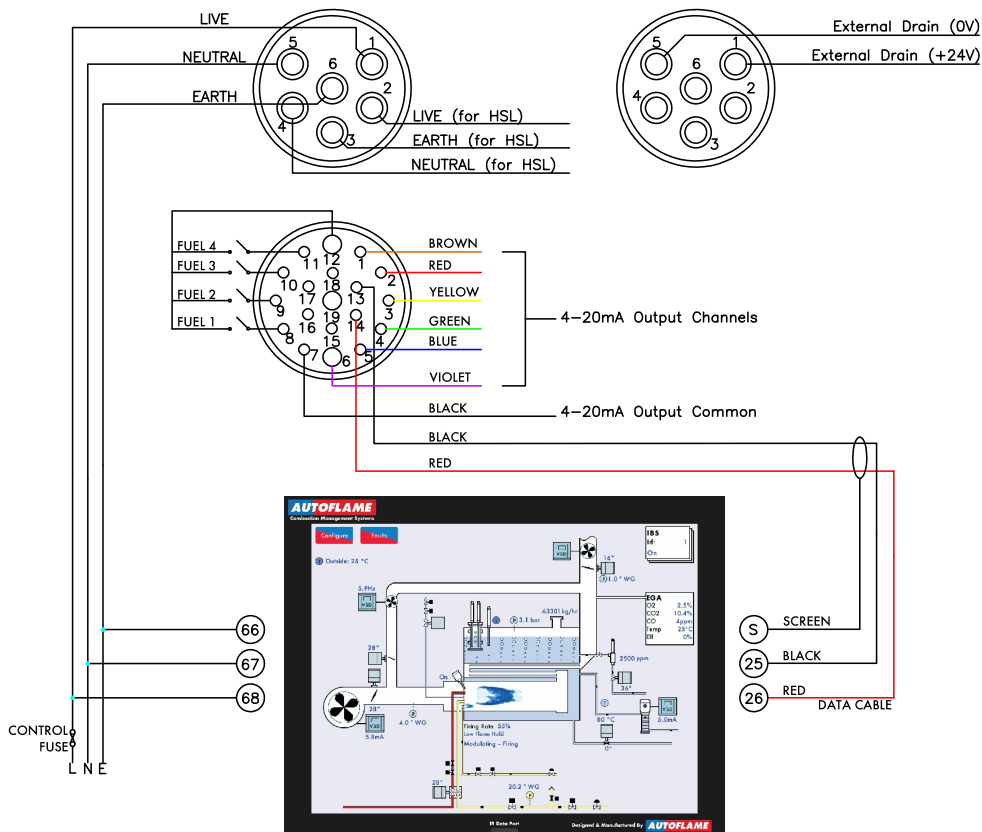
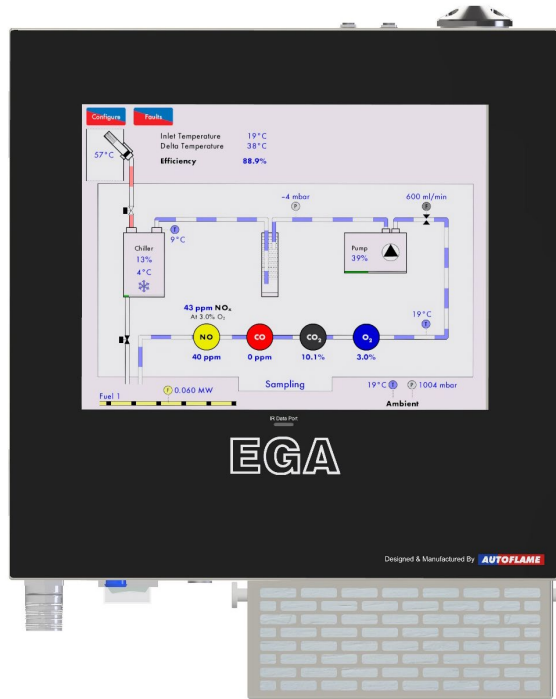

Drawing No. 7980

### 1.7.2 Connection between EGA, MM and DTI

The data cable should be screened at the MM and DTI end and connected all the way to the EGA plug; the screen from the flying lead provided should be connected to the data cables that connect to the MM and DTI.

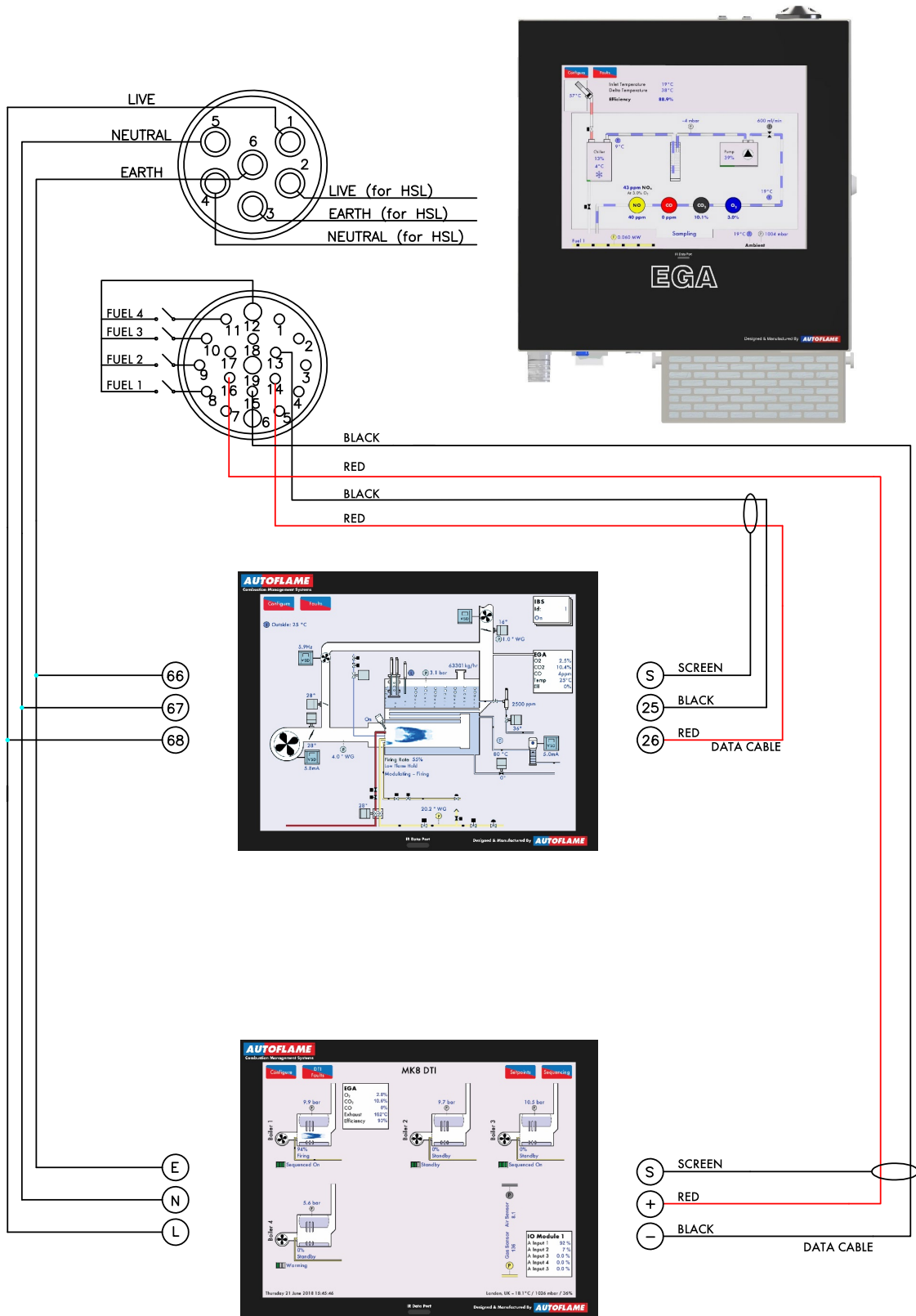

### 1.7.3 Connection between EGA and DTI

The data cable should be screened at the DTI end and connected all the way to the EGA plug; the screen from the flying lead provided should be connected to the data cables that connect to the DTI.

INTERCONNECTION BETWEEN STANDALONE  
E.G.A. MODULES AND D.T.I. MODULE

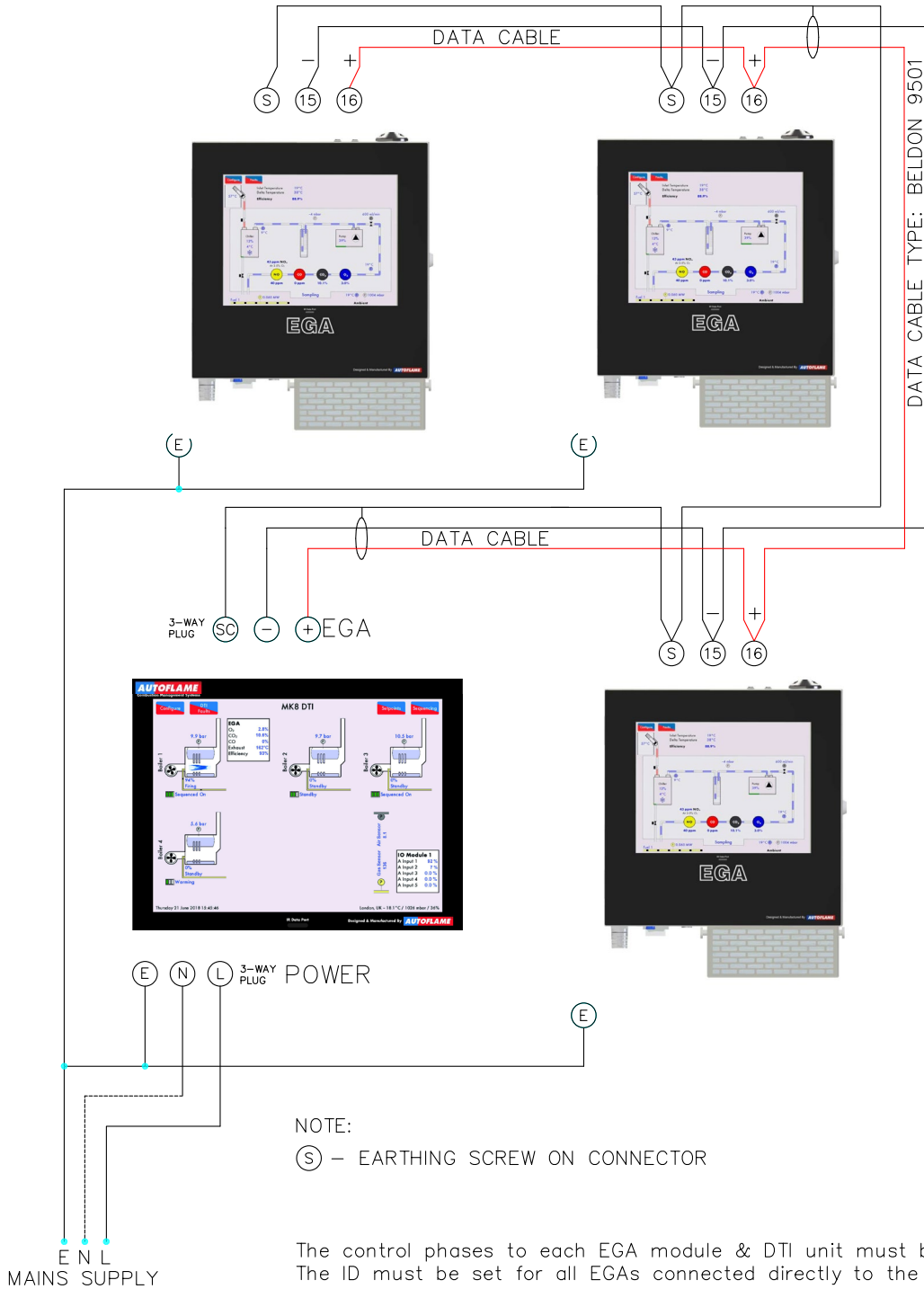

Drawing No. 7979

## 1.8 Ancillary Parts

### 1.8.1 Air Inlet Filter

The air inlet filter is designed to protect the EGA from dust and other particles that may cause damage or reduce the performance of the EGA over time. The air inlet filter will fit over the fan that cools the EGA and stop dust and particles from getting inside the EGA. The air inlet filter is easy to maintain with only the air filter material needing replacing once it has become saturated. The time between each change of air filter will depend on the site conditions.



*Figure 1.8.1.i Air Inlet Filter*

While the EGA can successfully be used to measure combustion exhaust gases when burning HFO, it is very important that the fuel is carefully maintained at a constant and known composition. The fuel temperature and pressure play a major role in the amount of particulate carry-over sampled, before combustion even takes place.

The burner must be regularly maintained to ensure complete combustion of the hydrocarbons. Failure to do so will result in premature failure of the EGA. Ensure the oil filter is regularly maintained and the oil nozzle is regularly inspected for fatigue.

It is recommended that when the EGA is used on a dual fuel application where natural gas is the primary fuel and HFO is the secondary fuel, the EGA should not be monitoring the HFO exhaust. This can be achieved by simply isolating the EGA when the HFO fuel is selected to be fired.



### 1.8.2 External Particulate Filter

The external particulate filter is designed to be used when there is excessive moisture from the flue gases, or if there is excess particulates in the flue gases which may cause damage to the EGA. The external particulate filter stops excessive moisture from getting into the EGA as it has its own drain solenoid to remove any excess moisture. This drain occurs at the same time intervals as the normal drain solenoid on the EGA.

The external particulate filter has its own filter, capable of filtering excess particulates from the flue gases. We recommend that this external particulate filter be used for any heavy oil applications. Due to the nature of this product it can only be installed by Autoflame and cannot be fitted on site.

The external particulate filter can be ordered with a new EGA or it can be ordered separately and fitted on site onto an existing Mk8 EGA Evo.



Figure 1.8.2.i External Particulate Filter

**Note:** For applications firing on heavy or dirty oil, an external particulate filter is highly recommended to be fitted with the EGA.

The external particulate filter will need to be changed depending on the amount of particulate carried over from the combustion process. This could be a month or as little as once every 6 months, once the filter starts to discolour. Use the Bacharach scale of 5 as an indication as to when the filters need to be changed.

The filter material is fluorocarbon resin bonded, borosilicate glass micro-fibre designed to coalesce liquid particles through a two layer construction. The inner layer forms the main filtration and the coarser layer provides drainage. It is a type MCE 95% 25micron high efficiency filter. The filter should be fitted as in the Figure 1.7.2.i ensuring that the filter operates correctly. Please note that there may be a discharge of liquid from the filter when in use. This is a design feature to drain any excess moisture from the flue before it reaches the EGA.

**The inlet from the flue is connected to the horizontal section on the top of the filter. The vertical section is connected directly to the EGA inlet.**

**External particulate filters should be used for applications firing on heavy or dirty oil, environments with dust and particulate, extremely cold or high humidity conditions.**

### 1.8.3 Chilled Environmental Enclosure

The exhaust gas is vented into the air stream leaving the EGA unit. This is located on the outside of the EGA enclosure next to the drain solenoid outlet. It is extremely important that the exhaust gas is vented into atmosphere; **do not install an EGA within a sealed enclosure**. Installing the EGA in a sealed enclosure will cause the EGA to calibrate on contaminated gases. The EGA will self-calibrate every 12 hours of running or when the burner starts and stops.

In areas of harsh ambient conditions, or excessive heat, it is necessary to use an environmental enclosure with the EGA module. This protects the EGA from dust and ensures that the EGA is well protected. Using the enclosures allows the EGA to operate under optimal operating conditions.

Autoflame manufacture a chilled environmental enclosure that uses a chiller module and control panel in order to maintain the EGA installed within the enclosure at a set temperature to protect itself from excessive heat. The temperature is user adjustable by means of a thermostat counted on the unit but is nominally set for 35°C (95°F), which ensures ideal operating conditions for the EGA. Autoflame also manufacture a heated enclosure for low temperature and for anti-condensing sites.

If you require further information please contact Autoflame Technical Support.

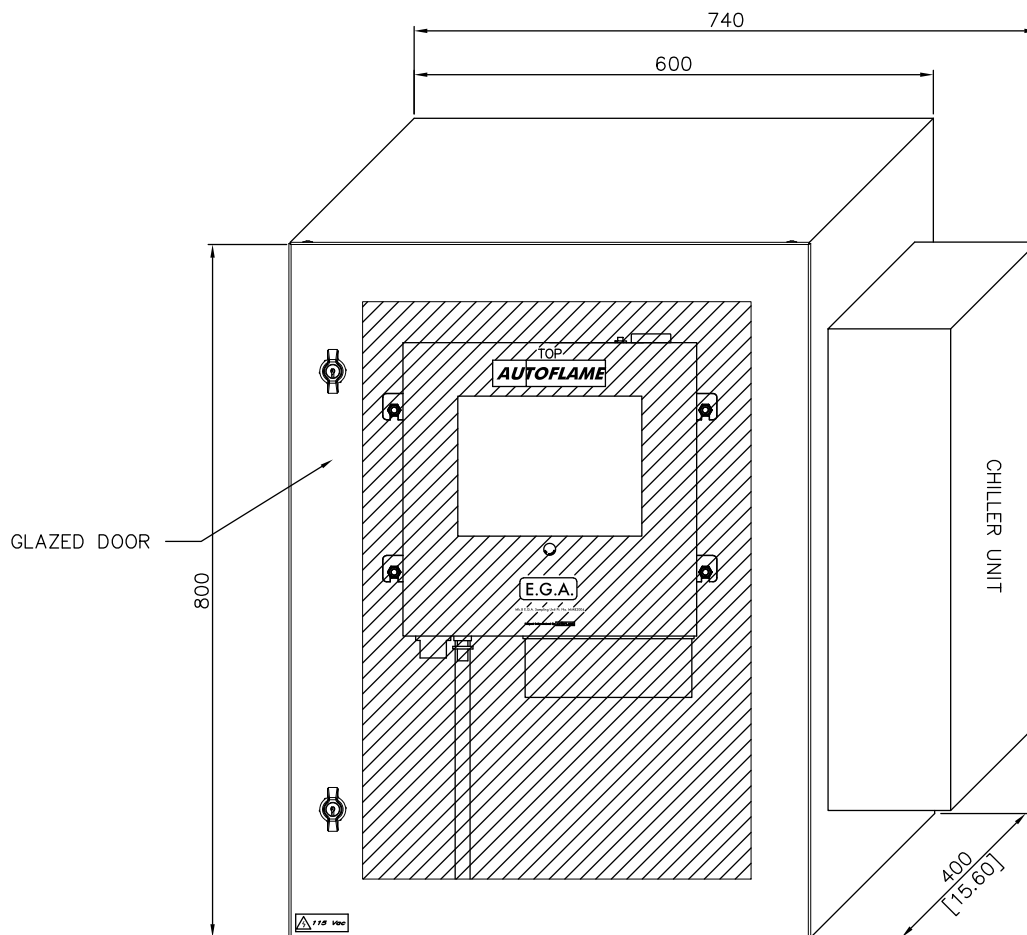

Figure 1.8.3.i Schematic of EGA Chilled Environmental Enclosure



*Figure 1.8.3.ii EGA Chilled Environmental Enclosure*

### 1.8.4 Pre-Heated Air Sensor

A pre-heated air sensor can be connected to the EGA to ensure an accurate combustion efficiency calculation when using pre-heated air to the burner. If the temperature of the air going into the burner is more than 40°C (104°F), a preheated air sensor is required.

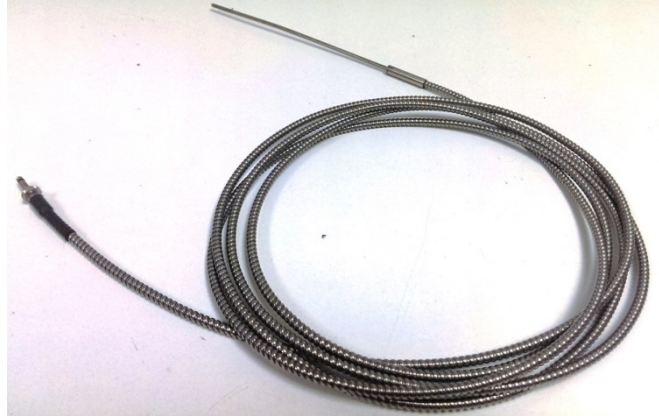

Figure 1.8.4.i Pre-Heat Air Sensor

The pre-heated air sensor uses a K-type thermocouple and the working temperature range is 0 – 400°C (32 – 752°F). The pre-heated air sensor will need to be enabled in Commission Mode setting 41, see section 2.2.1.

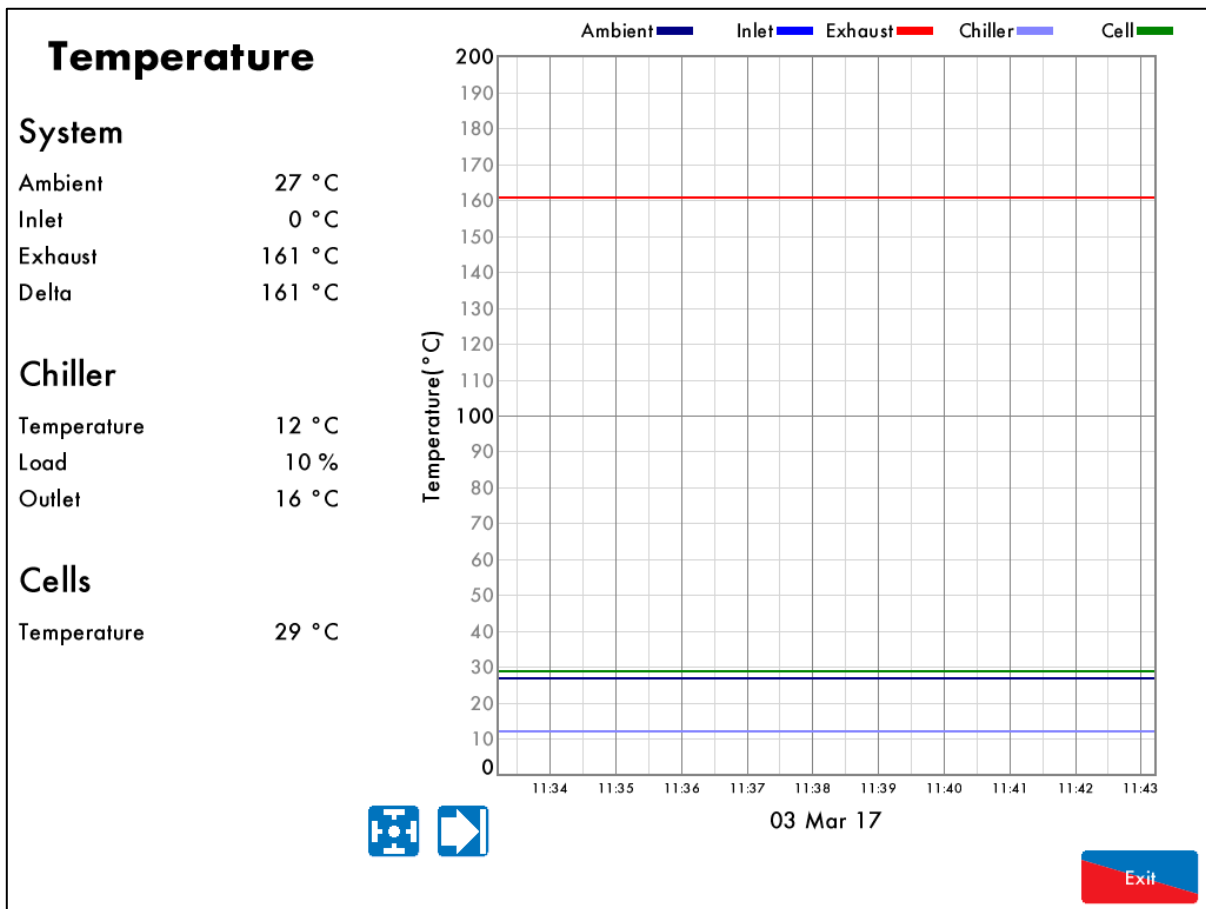

Figure 1.8.4.ii Temperature Screen with Pre-Heated Air Sensor Enabled

The EGA will separate the ambient temperature from the pre-heated air (inlet) temperature.

## 2 COMMISSIONING EGA

### 2.1 Operating Modes

#### 2.1.1 EGA through MM

When using an EGA with an MM, the EGA can be connected to the MM following the wiring schematic in section 1.7.1. The EGA must also be enabled in the MM settings. If the EGA is to be connected to a DTI as well, then the boilers on the DTI will need to set up with 'EGA fitted,' and modules connected following the wiring schematic in section 1.7.2.

When used with an MM, the EGA can be set to monitoring only, 3-parameter trim, or 3-parameter with combustion limits through option 12. If an EGA fault occurs, the burner can either shutdown or continue running depending on option 13. The table below shows the relevant options and parameters for on the MM for the EGA.

Options	Description
12	EGA Functionality
13	EGA Fault Response
18	Carry Forward of Trim
19	O <sub>2</sub> Upper Limit Offset
20	CO <sub>2</sub> Upper Limit Offset
21	CO Upper Limit Offset
22	O <sub>2</sub> Lower Limit Offset
23	CO <sub>2</sub> Lower Limit Offset
25	O <sub>2</sub> Absolute Limit
26	CO <sub>2</sub> Absolute Limit
27	CO Absolute Limit
28	Trim Threshold
32	Trim Delay
76	Trim Channel

Parameters	Description
4	Delay before EGA Commission Can Be Stored
8	Trim Delay After Drain
10	EGA Version
12	CO Used for Trim On Oil
13	Commission Fuel-Rich Trim
14	Trim Reset Angular Rate
17	Number of Trims Before Limits Error Generated
18	Maximum Trim During Run
19	Commission Air-Rich Trim
23	Add Air when CO Present
26	Trim Samples Per Cycle
94	NO Upper Limit Offset
96	Exhaust Temperature Upper Limit Offset
97	Exhaust Temperature Absolute Limit

Please refer to the MM Installation and Commissioning Guides for full description of these settings.

Please refer to section 4.3 for the 3-parameter trim function and section 4.5 for combustion limits.

When setting up a Mk8 EGA EVO with an MM, it must be ensured that both EGA and MM are setup with the same type of communication via Setting 40 on the EGA and Parameter 10 on the MM.

To set up communications between a Mk8 EGA EVO and a Mk8 or Mini Mk8 MM, Setting 40 on the EGA should be set to **0. Mk8 Protocol (RS485)** and Parameter 10 on the MM should be set to **2. Mk8 Protocol (RS485)**.

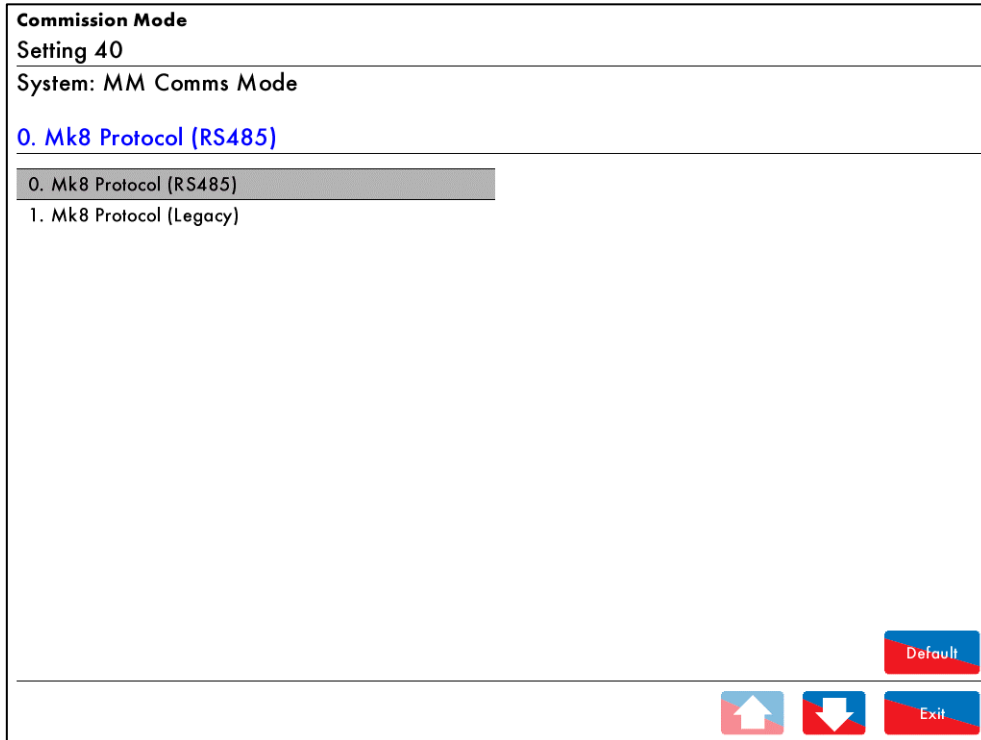

Figure 2.1.1 i: Setting 40 on the EGA

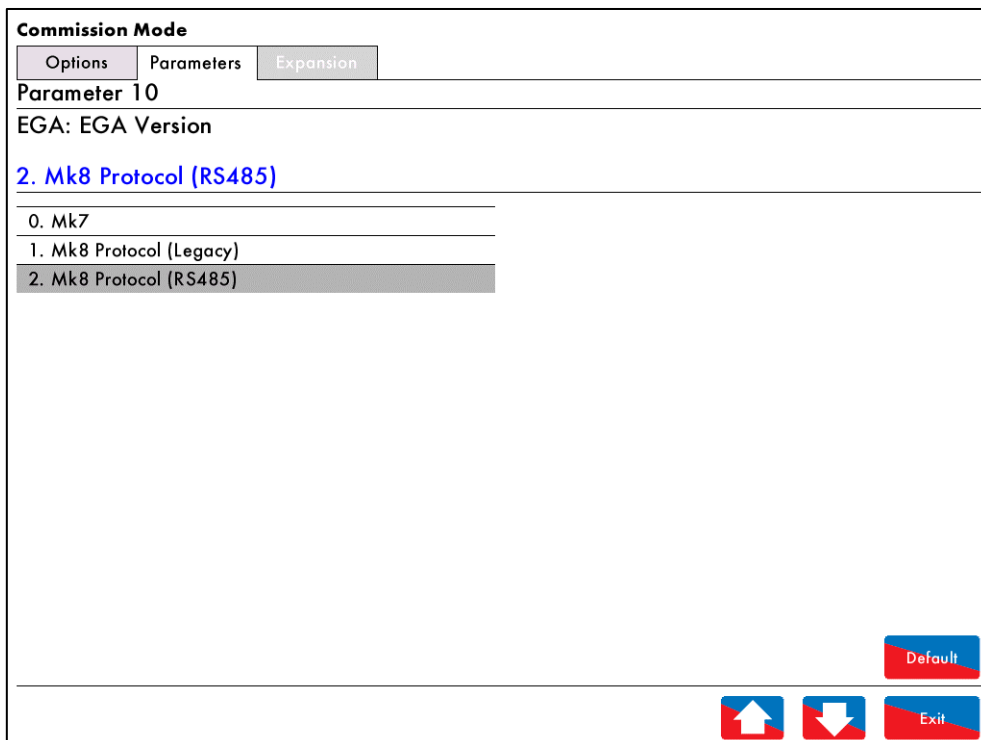

Figure 2.1.1 ii: Parameter 10 on the Mk8 or Mini Mk8 MM

### 2.1.2 Standalone EGA

If using the EGA as a standalone module, with or without a DTI, a fuel select input must be given to the EGA. This is done by connecting a link between the chosen fuel select input and the fuel input common. The EGA must also be set to standalone mode in setting 1, see section 2.3 for EGA Settings.

Fuel Select	Data Flying Lead Wiring
1	Pin 8 to pin 12
2	Pin 9 to pin 12
3	Pin 10 to pin 12
4	Pin 11 to pin 12

**Note:** When using an EGA in standalone mode, there is no 3-parameter trim function or combustion limits, this can only be set on the MM.

The standalone EGA will also require fuel flow input on pins 17 and 18 in the data flying lead, see section 2.2.2 for setting up the 4-20mA fuel flow inputs.

Up to 10 EGAs can be connected to the DTI to monitor the emissions remotely, without an MM. The EGAs will need to be connected to the DTI following the wiring schematic in section 1.6.3.

When adding boilers on the DTI, they should be set up to 'MM not fitted' and 'EGA fitted' on the DTI.

Please refer to the DTI Setup Guide for more information on adding EGAs to the DTI.

## 2.2 EGA Settings

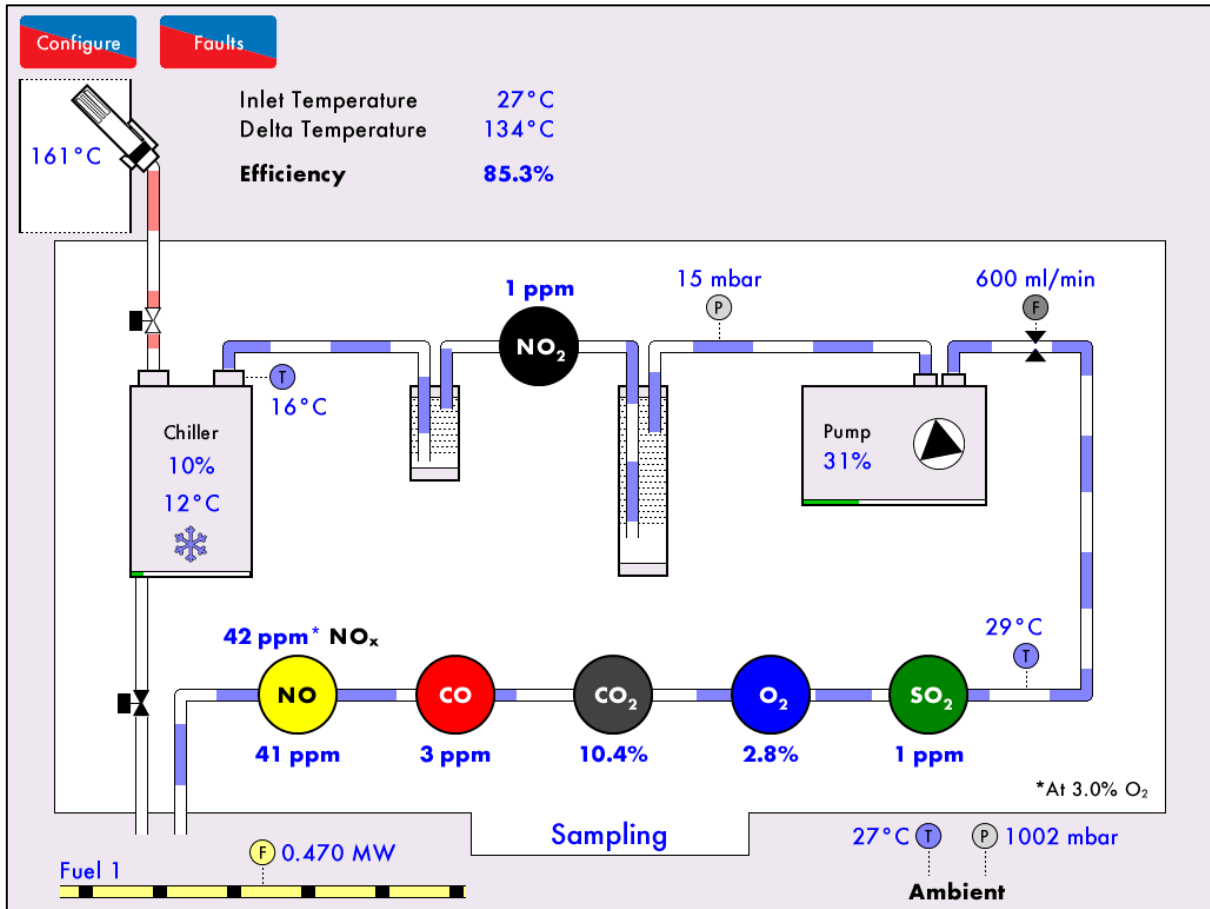



Figure 2.2.i Sampling Screen

When the EGA is first powered up and has loaded the data, the Sampling screen will appear. Press on

 to access the System Configuration screen.



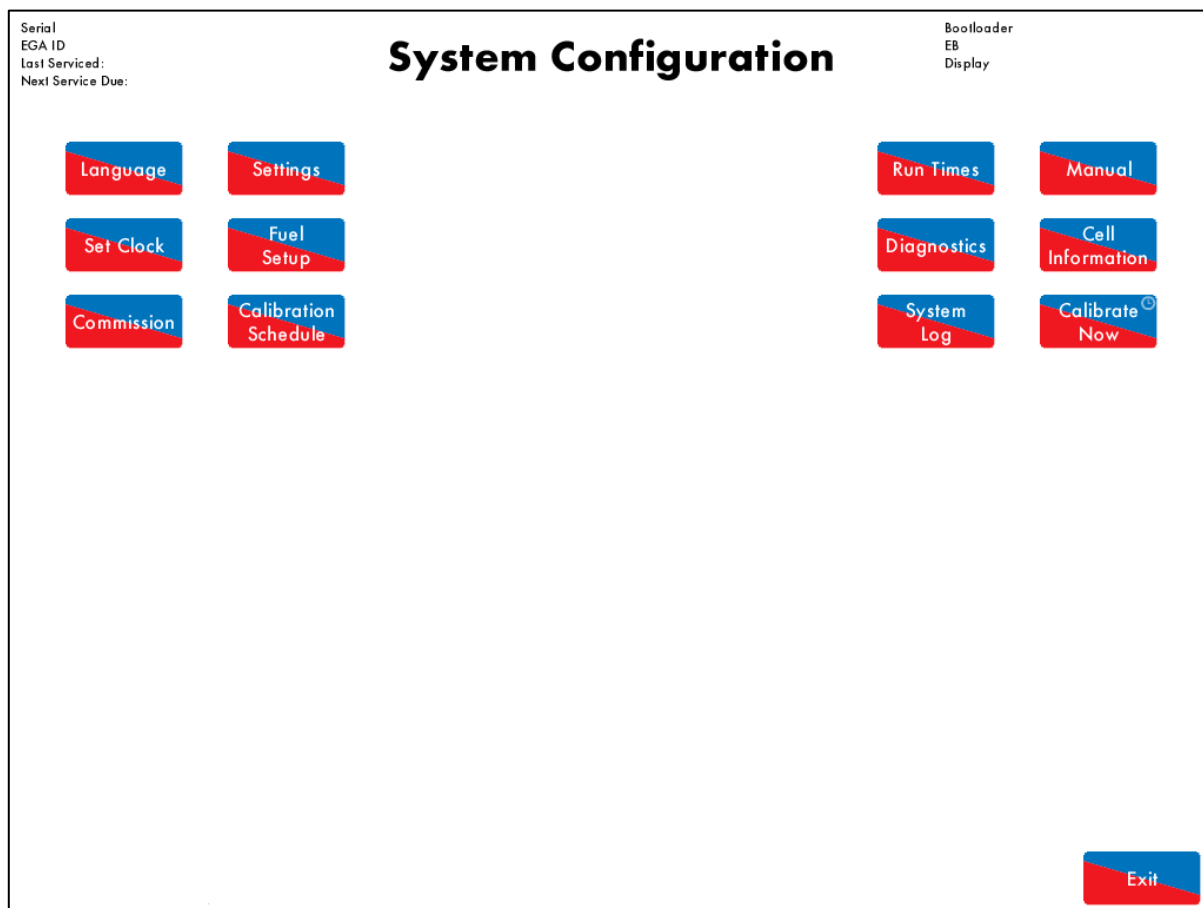



Figure 2.2.ii System Configuration Screen

Press  to access the Commissioning mode of the EGA. You will be prompted to enter the password.

The System Configuration provides information on:

- EGA Serial number
- EGA ID number (set in Commission Mode setting 2)
- Date of last service
- Date of next service
- Bootloader software version
- EB software version
- Display software version

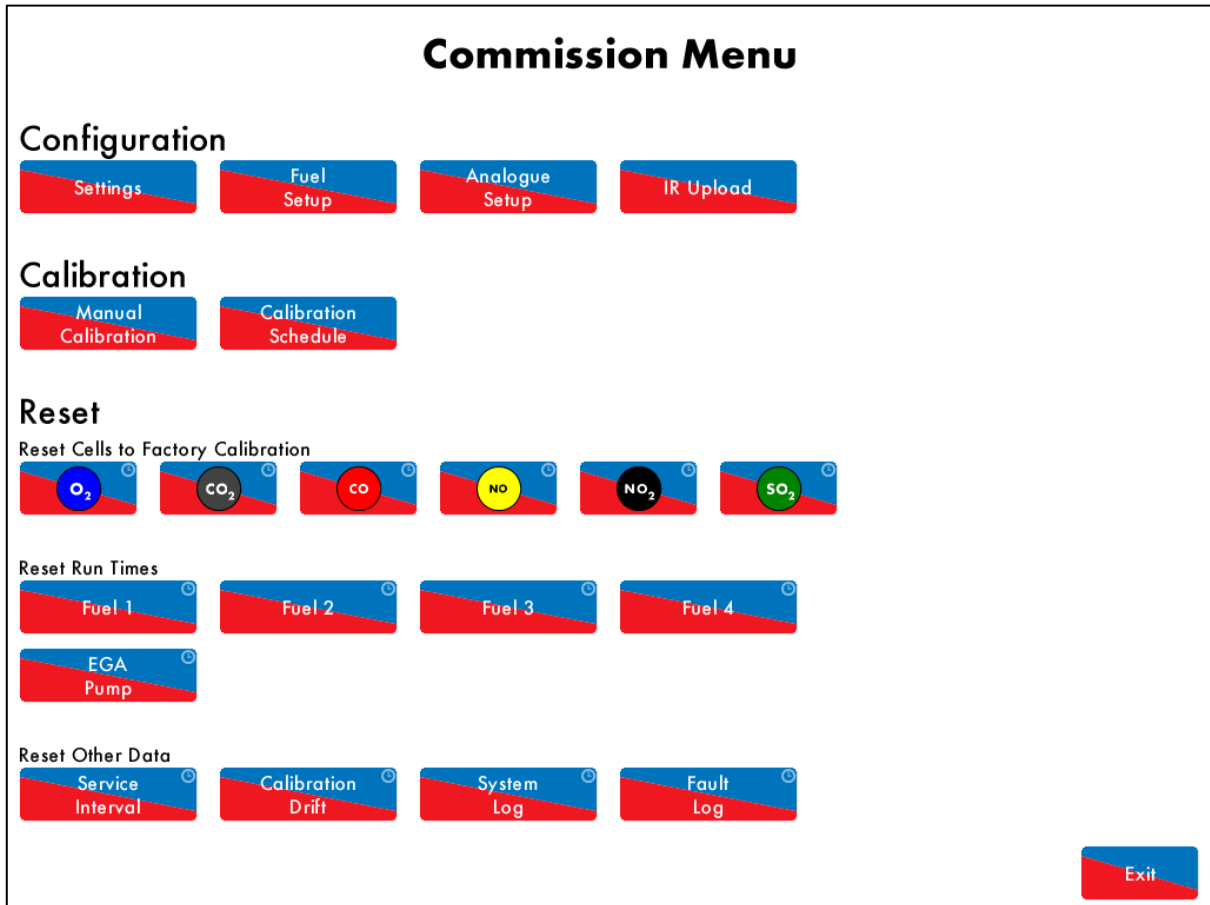

Figure 2.2.iii Commission Menu

In the Commission menu, the following can be changed according to the application requirements:

- EGA operational settings
- Fuel type, units and cost
- Analogue 4-20mA outputs
- Upload EGA settings to the unit
- Calibration schedule
- Reset cells to factory calibration
- Reset fuel run times, pump history, service interval period, calibration drift
- Reset system log and fault log

## 2.2.1 Commission Mode Settings

Commission Mode		
#	Description	Value
1	Base: Control Mode	Controlled by MM
2	Base: Communications Id	1
3	Base: Display Units	Metric
4	Base: Efficiency Calculation Method	English
5	Base: Currency Units	GBP
6	Base: Backlight On Time	600 seconds
7	Base: Logo Display Timer	600 seconds
8	Base: Show Advanced Values	Disabled
9	Base: Pollutant Concentration Units	ppm
10	Cells: CO Poison Detection	Enabled
11	Cells: CO Poison Limit	600 ppm
12	Cells: CO Poison Return	200 ppm
13	Cells: SO2 Correction	100%
14	Cells: Minimum NO2 Fraction of NOx (if NO2 cell fitted)	0%
15	Cells: Reference O2 Concentration	3.0% O2
16	Cells: NO Fraction of NOx (if NO2 cell not fitted)	94.0%
17	Cells: Standard Temperature	298.0 °K
18	Cells: Standard Pressure	1013.2 mbar (406.8 inWG)
19	Unused: Unused	0

All
Base
Cells
Calibration
Back box
System
Vendor









Figure 2.2.1.i Commission Mode

Press  in the Commission Menu to access the Commission Mode settings. The settings are grouped together in tabs: Base, Cells, Calibration, Back Box, System and Vendor.

Once settings have been changed, press  to return to the Commission Menu screen.

The below table shows the Commission Mode settings, range and their default values; these settings should be adjusted by factory trained technicians.

Setting	Default	Range	Description
1	0	0 1	<p><u>Control Mode</u></p> <p>The EGA can be used with an MM or as standalone. For setting 0, the fuel select comes from the MM; 3-parameter trim and combustion limits can also be set on the MM. For setting 1, a link between the fuel select input and fuel select common on the flying lead is required, and a 4-20mA fuel flow input is required for fuel consumption, see section 2.1 on operating modes.</p> <p>0 Controlled by MM 1 Standalone</p>
2	1	1 – 10	<p><u>Communications ID</u></p> <p>The ID number is used when the EGA is connected to a DTI. When multiple EGAs are connected to a DTI, each EGA will require a different ID number. Up to 10 EGAs can be connected to a DTI.</p> <p>ID number</p>
3	0	0 1	<p><u>Display Units</u></p> <p>The EGA can be viewed in metric or imperial units. Once the EGA has been running and data is stored, changing the units will invalidate existing data log files stored within the EGA.</p> <p>0 Metric 1 Imperial</p>
4	0	0 1	<p><u>Efficiency Calculation Method</u></p> <p>For setting 0, the hydrogen and moisture loss is taken into account in the combustion efficiency displayed on the EGA, and for setting 1, the hydrogen and moisture is not taken into account.</p> <p>0 English 1 European</p>
5	2	0 1 2 3 4 5 6 7 8	<p><u>Currency Units</u></p> <p>The currency units are used with fuel flow to determine the boiler's fuel consumption and how much it costs.</p> <p>0 USD (US Dollar) 1 EUR (European Single Currency) 2 GBP (British Pound Sterling) 3 CNY (Chinese Yuan) 4 CAD (Canadian Dollar) 5 AUD (Australian Dollar) 6 NZD (New Zealand Dollar) 7 KRW (South Korean Won) 8 ZAR (South African Rand)</p>
6	600	0 1 – 3600	<p><u>Backlight On Time</u></p> <p>If the screen is not pressed, and this timer elapses, the backlight will dim.</p> <p>0 Disabled 1 – 3600 Seconds</p>
7	600	0 1 – 3600	<p><u>Logo Display Timer</u></p> <p>If a custom logo is stored on the data SD card in the EGA, then after this timer elapses in idle mode, the custom logo will appear on the screen.</p> <p>0 Disabled 1 – 3600 Seconds</p>

Setting	Default	Range	Description
8	0	0 1	<u>Show Advanced Values</u> For setting 1, the fault code number is shown in the fault log. Disabled Enabled
9	0	0 1	<u>Pollutant Concentration Units</u> The units for the NO <sub>2</sub> , NO, CO and SO <sub>2</sub> cells can be displayed as ppm or mg/m <sup>3</sup> . For mg/m <sup>3</sup> , the exhaust gas concentrations are shown at the standard temperature and pressure set in commission mode settings 17 and 18, and corrected to reference O <sub>2</sub> set in commission mode setting 15. ppm mg/m <sup>3</sup>
10	1	0 1	<u>CO Poison Detection</u> For setting 0, no message will display when the CO ppm rises above the CO poison limit in setting 11. For setting 1, if the CO ppm is above the CO poison limit, the message 'Poisoned' will appear on the sampling screen for the CO cell. The cells will stop reading the exhaust gas readings until the CO ppm has decreased to the CO poison return level in setting 12. Disabled Enabled
11	600	100 – 1000	<u>CO Poison Limit</u> If setting 10 is set to 1, the message 'poisoned' will appear next to the CO cell on the sampling screen if the CO is above the limit set in this setting. CO ppm
12	200	50 – 950	<u>CO Poison Return</u> If setting 10 is set to 1, the message 'poisoned' next to the CO cell on the sampling screen will clear when the CO reaches the limit set in his setting. CO ppm
13	100	50 – 100	<u>SO<sub>2</sub> Correction</u> There may be a difference in the EGA SO <sub>2</sub> reading and a reading taken straight from the flue, as the water in the sample flowing down to the EGA will absorb a part of the SO <sub>2</sub> . The reading displayed on the EGA can be adjusted by changing this SO <sub>2</sub> correction. 50 – 100 %
14	0	0 – 10	<u>Minimum NO<sub>2</sub> Fraction of NO<sub>x</sub> (if NO<sub>2</sub> cell fitted)</u> Please contact Autoflame Engineering Ltd for more information. 0 – 10 %
15	30	1 – 200	<u>Reference O<sub>2</sub> Concentration</u> The NO <sub>x</sub> can be displayed normalised to a specific O <sub>2</sub> value on the EGA sampling screen. This reference O <sub>2</sub> concentration is also used to display the pollutants in mg/m <sup>3</sup> , see commission mode setting 9. 0.1 – 20.0 % O <sub>2</sub>
16	940	100 – 1000	<u>NO Fraction of NO<sub>x</sub> (if NO<sub>2</sub> cell not fitted)</u> If an optional NO <sub>2</sub> cell is not fitted, then the EGA will calculate the NO <sub>x</sub> in the exhaust gases, based on how much NO is part of the NO <sub>x</sub> . 10.0 – 100.0%

Setting	Default	Range	Description
17	2980	2000 – 4000	<u>Standard Temperature</u> The standard temperature and pressure values are used to calculate the volume flow of the gases, from their respective mass flows, and to convert the pollutant ppm concentrations to mg/m <sup>3</sup> , see commission mode setting 9. 200.0 – 400.0°K
18	10132	9000 - 11000	<u>Standard Pressure</u> The standard temperature and pressure values are used to calculate the volume flow of the gases, from their respective mass flows, and to convert the pollutant ppm concentrations to mg/m <sup>3</sup> , see commission mode setting 9. 900.0 – 1100.0 mbar (361.3 – 441.6" WG)
19	-	-	Unused
20	2095	1800 – 2200	<u>O<sub>2</sub> Air Calibration Value</u> When the EGA performs an air calibration, it will calibrate the O <sub>2</sub> cell to the value set for the O <sub>2</sub> calibration value. 18.00 – 22.00 %
21	360	20 – 2400	<u>Air Calibration Time</u> This is the time taken for the air calibration, when the EGA starts up, by calibration or it is forced into an air calibration. Air goes into the EGA via the drain solenoid valve. Seconds
22	-	-	Unused
23	1000	0 1 – 1000	<u>CO Span – Calibration Drift Reference</u> The calibration drift limit for the CO cell is 5.0% of the calibration drift reference set in this setting. If a single cell calibration reaches 4 times the calibration limit or if it reaches 2 times the limit for 5 consecutive days, an excess drift fault will occur. Disabled CO ppm
24	500	0 1 – 1000	<u>NO Span – Calibration Drift Reference</u> The calibration drift limit for the NO cell is 2.5% of the calibration drift reference set in this setting. If a single cell calibration reaches 4 times the calibration limit or if it reaches 2 times the limit for 5 consecutive days, an excess drift fault will occur. Disabled NO ppm
25	500	0 1 – 1000	<u>NO<sub>2</sub> Span – Calibration Drift Reference</u> The calibration drift limit for the NO <sub>2</sub> cell is 2.5% of the calibration drift reference set in this setting. If a single cell calibration reaches 4 times the calibration limit or if it reaches 2 times the limit for 5 consecutive days, an excess drift fault will occur. Disabled NO <sub>2</sub> ppm

Setting	Default	Range	Description
26	1000	0 1 – 1000	<u>SO<sub>2</sub> Span – Calibration Drift Reference</u> The calibration drift limit for the SO <sub>2</sub> cell is 2.5% of the calibration drift reference set in this setting. If a single cell calibration reaches 4 times the calibration limit or if it reaches 2 times the limit for 5 consecutive days, an excess drift fault will occur. Disabled SO <sub>2</sub> ppm
27	-	-	Unused
28	-	-	Unused
29	-	-	Unused
30	1	0 1	<u>Heated Sample Line Mode</u> If a self-calibration EPA EGA is purchased, then a Heated Sampling Line is also required. This setting sets whether the HSL is used for monitoring the temperature of the exhaust gases or maintaining the exhaust gas temperature to the value set in setting 31, before they reach the EGA. Off (Monitoring only) On (Temperature control)
31	110	0 – 200	<u>Heated Sample Line Target</u> If a self-calibration EPA EGA is purchased, then a Heated Sampling Line is also required. If setting 30 is set to 1, then the Heated Sampling Line will try to maintain the target temperature value set this setting. 0 – 200°C (32 – 392°F)
32	-	-	Unused
33	-	-	Unused
34	-	-	Unused
35	-	-	Unused
36	-	-	Unused
37	-	-	Unused
38	-	-	Unused
39	-	-	Unused
40	0	0 1	<u>MM Comms Mode</u> If the EGA is connected to a Mk8 MM or Mini Mk8 MM, then this setting should be set to RS485, and parameter 10 on the MMs should be set to Mk8 Protocol (RS485). If the EGA is connected to a Mk7 MM or Mini Mk7 MM, then this setting should be set to Legacy, and parameter 10 on the MMs should be set to Mk8 rev 3. Mk8 Protocol (RS485) Mk8 Protocol (Legacy)

Setting	Default	Range	Description
41	0	0 1	<u>Preheated Air Sensor</u> If the temperature of the air going into the burner is more than 40°C (104°F), a preheated air sensor is required. For setting 1, the EGA will separate the ambient temperature from the preheated air temperature in the displayed graphs on the EGA. Disabled Enabled
42	30	5 – 240	<u>Reading Hold Time</u> Following a drain or calibration, the cells will allow the time set in this setting for the readings to settle, before they update on the EGA screen. Seconds
43	240	60 – 3600	<u>Time Between Drains While Sampling</u> This setting sets the time period between the drain solenoid valve opening to drain out the excess moisture in the sample, while the EGA is sampling. If the sample has too much moisture, then reduce this time so the EGA drains more often. Seconds
44	600	60 – 3600	<u>Time Between Drains While Idle</u> This setting sets the time period between the drain solenoid valve opening to drain out the excess moisture in the sample, when the EGA is idle. Seconds
45	600	0 1 – 1800	<u>Idle Transition Time</u> When a fuel is deselected, or the MM has shut down the burner, this setting allows some time before the EGA goes into idle mode. This transition time allows the EGA to calculate the combustion efficiency when there are still leftover exhaust gases in the stack. Disabled Seconds
46	0	0 1	<u>Forced Drain Using Self-Calibration Pump</u> If a self-calibration EPA EGA is purchased, then when the EGA performs a drain, this setting allows the self-calibration to also force water out of the EGA drain. Disabled Enabled
47	25	0 – 50	<u>Inlet Pressure Fault Tolerance</u> If the inlet pressure to the EGA drops below the value set in this setting, then a 'input blocked' fault will occur. 0 – 50mbar (0 – 20"WG)
48	1100	900 – 1200	<u>Barometer Limit</u> The barometric pressure sensor measures the pressure in the sample line, and indicates if the sample line is blocked. If the barometric pressure goes above the limit set in this value, an 'output blocked' fault will occur. 900 – 1200 mbar (361 – 482"WG)
49	0	0 1	<u>Burner Detection Firing Method</u> If an EGA is to be installed prior to the MM, then this setting allows the EGA to run without a fuel flow meter input for CEMS logging. Fuel Flow CO <sub>2</sub> Threshold (3%)



Setting	Default	Range	Description
50	***	0 – 255	<u>Password Code 1</u>
51	***	0 – 255	<u>Password Code 2</u>
52	***	0 – 255	<u>Online Changes Code 1</u>
53	***	0 - 255	<u>Online Changes Code 2</u>
54	24	3 – 24	<u>Service Interval</u> A message will appear on the screen if the EGA has reached its service interval time set in this setting. Months
55	0	0 1 – 12	<u>Service Interval Error Period</u> This setting sets how long the EGA continues to run after the service interval period in setting 54 has elapsed. Disabled Months
56	0	0 1	<u>Modbus Data Format</u> The Modbus data format on the EGA should be set the same as the baud rate used on the external Modbus communication program. Binary Format ASCII Format
57	1	1 – 247	<u>Modbus Device ID</u> This ID is used to recognise the device on the external Modbus communication program.
58	0	0 1	<u>Modbus Baud Rate</u> The baud rate on the EGA should be set the same as the baud rate used on the external Modbus communication program. 9600 Baud 19200 Baud
59	0	0 1 2	<u>Modbus Parity Setting</u> The parity on the EGA should be set the same as the baud rate used on the external Modbus communication program. No parity Odd parity Even parity
60			<u>Vendor Details Line 1</u> Enter Vendor Name
61			<u>Vendor Details Line 2</u> Enter Address Details (Street)
62			<u>Vendor Details Line 3</u> Enter Address Details (Town /City /Zip)

Setting	Default	Range	Description
63			<u>Vendor Details Line 4</u> Enter Contact Details (Phone /Email Address)
64	-	-	Unused
65	-	-	Unused
66	-	-	Unused
67	-	-	Unused
68	-	-	Unused
69	-	-	Unused
70	0	0 – 100	<u>Factory Restore</u> Setting 5 will reset all settings to factory default.

## 2.2.2 Fuel Setup Settings

The fuel flow for the EGA can be taken from the MM (if connected) or by a 4-20mA fuel flow input on pins 17 and 18. The fuel type and cost can also be set on the EGA for CEMS analysis.

If the fuel flow input is used, then the 4-20mA input must be configured.

Fuel Setup		
#	Description	Value
1	Fuel 1: Fuel Type	Natural Gas (Birmingham, AL)
2	Fuel 1: Costing Units	1000 ft <sup>3</sup>
3	Fuel 1: Cost Per Unit	10.00 GBP/1000 ft <sup>3</sup>
4	Fuel 1: Fuel Flow Source	MM
5	Fuel 1: Fuel Flow Meter Units	MW
6	Fuel 1: Fuel Flow Meter Min At 4mA	0.00 MW
7	Fuel 1: Fuel Flow Meter Max At 20mA	0.00 MW
8	Unused: Unused	0
9	Unused: Unused	0
10	Unused: Unused	0
11	Fuel 2: Fuel Type	Natural Gas (Birmingham, AL)
12	Fuel 2: Costing Units	1000 ft <sup>3</sup>
13	Fuel 2: Cost Per Unit	10.00 GBP/1000 ft <sup>3</sup>
14	Fuel 2: Fuel Flow Source	MM
15	Fuel 2: Fuel Flow Meter Units	MW
16	Fuel 2: Fuel Flow Meter Min At 4mA	0.00 MW
17	Fuel 2: Fuel Flow Meter Max At 20mA	0.00 MW
18	Unused: Unused	0
19	Unused: Unused	0
20	Unused: Unused	0

All   Fuel 1   Fuel 2   Fuel 3   Fuel 4





  

Figure 2.2.2.i

Press  in the Commission Menu screen to access the Fuel Setup settings. The settings are grouped together in tabs by fuel 1, fuel 2, fuel 3 and fuel 4.

Once settings have been changed, press  to return to the Commission Menu screen.

The below table shows the Fuel Setup settings, range and their default values.

Setting	Default	Range	Description
1	0		<u>Fuel 1: Fuel Type</u> 0 Natural Gas (Birmingham, AL) 1 Natural Gas (North Sea) 2 Natural Gas (Pittsburgh, PA) 3 Butane 4 Digester Gas 5 Heavy Fuel Oil #6 6 Light Fuel Oil #2 7 Propane (More information on fuels can be found in at the end of this table.)
2	0		<u>Fuel 1: Costing Units</u> 0 1000 ft <sup>3</sup> 1 MMBtu 2 MWh 3 m <sup>3</sup> 4 US gallons 5 Litres
3	1000	0 – 65535	<u>Fuel 1: Cost Per Unit</u> The currency units is set in Commission Mode setting 5, see section 2.2.1. 0.00 – 655.35 currency per costing unit The default value is 10.00 GBP /1000 ft <sup>3</sup>
4	0		<u>Fuel 1: Fuel Flow Source</u> For setting 0, the EGA is connected to an MM and the fuel flow rate is received from the MM's fuel flow rate based on fuel flow metering. For setting 1, a fuel flow meter is connected to the EGA via a 4-20mA input on pins 17 and 18 in the data flying lead. 0 MM 1 Fuel Flow Meter
5	0		<u>Fuel 1: Fuel Flow Meter Units</u> Setting 5 must be set if setting 4 is set to fuel flow meter. 0 MW 1 MMBtu/h 2 ft <sup>3</sup> /h 3 m <sup>3</sup> /h 4 lb/h 5 kg/h 6 litres/h 7 US gallons/h
6	0	0 – 65535	<u>Fuel 1: Fuel Flow Meter Min at 4mA</u> 0.00 – 655.35 fuel flow meter units set in setting 5
7	0	0 – 65535	<u>Fuel 1: Fuel Flow Meter Max at 20mA</u> 0.00 – 655.35 fuel flow meter units set in setting 5
8	-	-	Unused
9	-	-	Unused
10	-	-	Unused

Setting	Default	Range	Description
11	0		<u>Fuel 2: Fuel Type</u> Natural Gas (Birmingham, AL) Natural Gas (North Sea) Natural Gas (Pittsburgh, PA) Butane Digester Gas Heavy Fuel Oil #6 Light Fuel Oil #2 Propane (More information on fuels can be found in at the end of this table.)
12	0		<u>Fuel 2: Costing Units</u> 0 1000 ft <sup>3</sup> 1 MMBtu 2 MWh 3 m <sup>3</sup> 4 US gallons 5 Litres
13	1000	0 – 65535	<u>Fuel 2: Cost Per Unit</u> The currency units is set in Commission Mode setting 5, see section 2.2.1. 0.00 – 655.35 currency per costing unit The default value is 10.00 GBP /1000 ft <sup>3</sup>
14	0		<u>Fuel 2: Fuel Flow Source</u> For setting 0, the EGA is connected to an MM and the fuel flow rate is received from the MM's fuel flow rate based on fuel flow metering. For setting 1, a fuel flow meter is connected to the EGA via a 4-20mA input on pins 17 and 18 in the data flying lead. 0 MM 1 Fuel Flow Meter
15	0		<u>Fuel 2: Fuel Flow Meter Units</u> Setting 15 must be set if setting 14 is set to fuel flow meter. 0 MW 1 MMBtu/h 2 ft <sup>3</sup> /h 3 m <sup>3</sup> /h 4 lb/h 5 kg/h 6 litres/h 7 US gallons/h
16	0	0 – 65535	<u>Fuel 2: Fuel Flow Meter Min at 4mA</u> 0.00 – 655.35 fuel flow meter units set in setting 15
17	0	0 – 65535	<u>Fuel 2: Fuel Flow Meter Max at 20mA</u> 0.00 – 655.35 fuel flow meter units set in setting 15
18	-	-	Unused
19	-	-	Unused
20	-	-	Unused

Setting	Default	Range	Description
21	0		<u>Fuel 3: Fuel Type</u>
		0	Natural Gas (Birmingham, AL)
		1	Natural Gas (North Sea)
		2	Natural Gas (Pittsburgh, PA)
		3	Butane
		4	Digester Gas
		5	Heavy Fuel Oil #6
		6	Light Fuel Oil #2
		7	Propane
			(More information on fuels can be found in at the end of this table.)
22	0		<u>Fuel 3: Costing Units</u>
		0	1000 ft <sup>3</sup>
		1	MMBtu
		2	MWh
		3	m <sup>3</sup>
		4	US gallons
		5	Litres
23	1000		<u>Fuel 3: Cost Per Unit</u>
			The currency units is set in Commission Mode setting 5, see section 2.2.1.
		0 – 65535	0.00 – 655.35 currency per costing unit The default value is 10.00 GBP /1000 ft <sup>3</sup>
24	0		<u>Fuel 3: Fuel Flow Source</u>
			For setting 0, the EGA is connected to an MM and the fuel flow rate is received from the MM's fuel flow rate based on fuel flow metering. For setting 1, a fuel flow meter is connected to the EGA via a 4-20mA input on pins 17 and 18 in the data flying lead.
		0	MM
		1	Fuel Flow Meter
25	0		<u>Fuel 3: Fuel Flow Meter Units</u>
			Setting 25 must be set if setting 24 is set to fuel flow meter.
		0	MW
		1	MMBtu/h
		2	ft <sup>3</sup> /h
		3	m <sup>3</sup> /h
		4	lb/h
		5	kg/h
		6	litres/h
		7	US gallons/h
26	0		<u>Fuel 3: Fuel Flow Meter Min at 4mA</u>
		0 – 65535	0.00 – 655.35 fuel flow meter units set in setting 25
27	0		<u>Fuel 3: Fuel Flow Meter Max at 20mA</u>
		0 – 65535	0.00 – 655.35 fuel flow meter units set in setting 25
28	-	-	Unused
29	-	-	Unused
30	-	-	Unused

Setting	Default	Range	Description
31	0		<u>Fuel 4: Fuel Type</u>
		0	Natural Gas (Birmingham, AL)
		1	Natural Gas (North Sea)
		2	Natural Gas (Pittsburgh, PA)
		3	Butane
		4	Digester Gas
		5	Heavy Fuel Oil #6
		6	Light Fuel Oil #2
		7	Propane
			(More information on fuels can be found in at the end of this table.)
32	0		<u>Fuel 4: Costing Units</u>
		0	1000 ft <sup>3</sup>
		1	MMBtu
		2	MWh
		3	m <sup>3</sup>
		4	US gallons
		5	Litres
33	1000		<u>Fuel 4: Cost Per Unit</u>
			The currency units is set in Commission Mode setting 5, see section 2.2.1.
		0 – 65535	0.00 – 655.35 currency per costing unit The default value is 10.00 GBP /1000 ft <sup>3</sup>
34	0		<u>Fuel 4: Fuel Flow Source</u>
			For setting 0, the EGA is connected to an MM and the fuel flow rate is received from the MM's fuel flow rate based on fuel flow metering. For setting 1, a fuel flow meter is connected to the EGA via a 4-20mA input on pins 17 and 18 in the data flying lead.
		0	MM
		1	Fuel Flow Meter
35	0		<u>Fuel 4: Fuel Flow Meter Units</u>
			Setting 35 must be set if setting 34 is set to fuel flow meter.
		0	MW
		1	MMBtu/h
		2	ft <sup>3</sup> /h
		3	m <sup>3</sup> /h
		4	lb/h
		5	kg/h
		6	litres/h
		7	US gallons/h
36	0		<u>Fuel 4: Fuel Flow Meter Min at 4mA</u>
		0 – 65535	0.00 – 655.35 fuel flow meter units set in setting 35
37	0		<u>Fuel 4: Fuel Flow Meter Max at 20mA</u>
		0 – 65535	0.00 – 655.35 fuel flow meter units set in setting 35
38	-	-	Unused
39	-	-	Unused
40	-	-	Unused

The below table shows information on the fuel type set in Fuel Setup settings 1, 11, 21 and 31, for fuels 1, 2, 3 and 4, respectively.

Fuel Type	Calorific Value (MJ/kg)	Specific Gravity	Composition by weight		
			C %	H <sub>2</sub> %	S %
Natural Gas (Birmingham, AL)	50.90	0.60	71.70	23.30	0.00
Natural Gas (North Sea)	50.86	0.59	69.40	22.50	0.00
Natural Gas (Pittsburgh, PA)	50.13	0.63	75.70	23.50	0.00
Butane	48.49	2.02	83.50	16.50	0.00
Digester Gas	19.09	0.80	60.41	13.40	0.00
Heavy Fuel Oil #6	42.23	0.96	88.30	9.30	0.85
Light Fuel Oil #2	44.25	0.83	87.30	12.50	0.20
Propane	50.27	1.52	81.60	18.40	0.00



### 2.2.3 Analogue Setup Settings

Analogue Setup		
#	Description	Value
1	Output 1: Data Source	Oxygen Concentration
2	Output 1: 4mA Corresponds To	0.0% O <sub>2</sub>
3	Output 1: 20mA Corresponds To	0.0% O <sub>2</sub>
4	Unused: Unused	0
5	Unused: Unused	0
6	Output 2: Data Source	Oxygen Concentration
7	Output 2: 4mA Corresponds To	0.0% O <sub>2</sub>
8	Output 2: 20mA Corresponds To	0.0% O <sub>2</sub>
9	Unused: Unused	0
10	Unused: Unused	0
11	Output 3: Data Source	Oxygen Concentration
12	Output 3: 4mA Corresponds To	0.0% O <sub>2</sub>
13	Output 3: 20mA Corresponds To	0.0% O <sub>2</sub>
14	Unused: Unused	0
15	Unused: Unused	0
16	Output 4: Data Source	Oxygen Concentration
17	Output 4: 4mA Corresponds To	0.0% O <sub>2</sub>
18	Output 4: 20mA Corresponds To	0.0% O <sub>2</sub>
19	Unused: Unused	0
20	Unused: Unused	0





All    Output 1    Output 2    Output 3    Output 4    Output 5    Output 6      

Figure 2.2.3.i Analogue Setup Screen

Press  in the Commission Menu screen to access the Analogue Setup screen. There are 6 analogue outputs available on the EGA, which can be configured to send data as 4-20mA from the EGA. The Analogue Setup settings are grouped together in tabs as Output 1, Output 2, Output 3, Output 4, Output 5 and Output 6.

Once settings have been changed, press  to return to the Commission Menu screen.

The table below shows the settings, range and default values for the Analogue Setup settings.

Setting	Default	Range	Description
1	0		<u>Output 1: Data Source</u> 0 Oxygen Concentration 1 Carbon Dioxide Concentration 2 Carbon Monoxide Concentration 3 Nitric Oxide Concentration 4 Nitrogen Dioxide Concentration 5 Sulphur Dioxide Concentration 6 Ambient Temperature 7 Exhaust Temperature 8 Efficiency 9 EGA Status
2	0		<u>Output 1: 4mA Corresponds To</u> For this setting, the units will depend on the data source in setting 1. 0 – 1000 0.0 – 100.0 % O <sub>2</sub> 0 – 1000 0.0 – 100.0 % CO <sub>2</sub> 0 - 10000 0 – 10000 ppm CO 0 - 10000 0 – 10000 ppm NO 0 - 10000 0 – 10000 ppm NO <sub>2</sub> 0 - 10000 0 – 10000 ppm SO <sub>2</sub> 0 – 10000 0.0 – 1000.0 °C Temperature 0 – 10000 0.0 – 1000.0 °F Temperature 0 – 1000 0.0 – 100.0 % Efficiency 0 – 1 0 = Off – 1 = On EGA Status
3	0		<u>Output 1: 20mA Corresponds To</u> For this setting, the units will depend on the data source in setting 1. 0 – 1000 0.0 – 100.0 % O <sub>2</sub> 0 – 1000 0.0 – 100.0 % CO <sub>2</sub> 0 - 10000 0 – 10000 ppm CO 0 - 10000 0 – 10000 ppm NO 0 - 10000 0 – 10000 ppm NO <sub>2</sub> 0 - 10000 0 – 10000 ppm SO <sub>2</sub> 0 – 10000 0.0 – 1000.0 °C Temperature 0 – 10000 0.0 – 1000.0 °F Temperature 0 – 1000 0.0 – 100.0 % Efficiency 0 – 1 0 = Off – 1 = On EGA Status
4	-	-	Unused
5	-	-	Unused

Setting	Default	Range	Description
6	0		<u>Output 2: Data Source</u>
		0	Oxygen Concentration
		1	Carbon Dioxide Concentration
		2	Carbon Monoxide Concentration
		3	Nitric Oxide Concentration
		4	Nitrogen Dioxide Concentration
		5	Sulphur Dioxide Concentration
		6	Ambient Temperature
		7	Exhaust Temperature
		8	Efficiency
		9	EGA Status
7	0		<u>Output 2: 4mA Corresponds To</u>
			For this setting, the units will depend on the data source in setting 6.
		0 – 1000	0.0 – 100.0 % O <sub>2</sub>
		0 – 1000	0.0 – 100.0 % CO <sub>2</sub>
		0 - 10000	0 – 10000 ppm CO
		0 - 10000	0 – 10000 ppm NO
		0 - 10000	0 – 10000 ppm NO <sub>2</sub>
		0 - 10000	0 – 10000 ppm SO <sub>2</sub>
		0 – 10000	0.0 – 1000.0 °C Temperature
		0 – 10000	0.0 – 1000.0 °F Temperature
		0 – 1000	0.0 – 100.0 % Efficiency
		0 – 1	0 = Off – 1 = On EGA Status
8	0		<u>Output 2: 20mA Corresponds To</u>
			For this setting, the units will depend on the data source in setting 6.
		0 – 1000	0.0 – 100.0 % O <sub>2</sub>
		0 – 1000	0.0 – 100.0 % CO <sub>2</sub>
		0 - 10000	0 – 10000 ppm CO
		0 - 10000	0 – 10000 ppm NO
		0 - 10000	0 – 10000 ppm NO <sub>2</sub>
		0 - 10000	0 – 10000 ppm SO <sub>2</sub>
		0 – 10000	0.0 – 1000.0 °C Temperature
		0 – 10000	0.0 – 1000.0 °F Temperature
		0 – 1000	0.0 – 100.0 % Efficiency
		0 – 1	0 = Off – 1 = On EGA Status
9	-	-	Unused
10	-	-	Unused

Setting	Default	Range	Description
11	0		<u>Output 3: Data Source</u>
		0	Oxygen Concentration
		1	Carbon Dioxide Concentration
		2	Carbon Monoxide Concentration
		3	Nitric Oxide Concentration
		4	Nitrogen Dioxide Concentration
		5	Sulphur Dioxide Concentration
		6	Ambient Temperature
		7	Exhaust Temperature
		8	Efficiency
		9	EGA Status
12	0		<u>Output 3: 4mA Corresponds To</u>
			For this setting, the units will depend on the data source in setting 11.
		0 – 1000	0.0 – 100.0 % O <sub>2</sub>
		0 – 1000	0.0 – 100.0 % CO <sub>2</sub>
		0 - 10000	0 – 10000 ppm CO
		0 - 10000	0 – 10000 ppm NO
		0 - 10000	0 – 10000 ppm NO <sub>2</sub>
		0 - 10000	0 – 10000 ppm SO <sub>2</sub>
		0 – 10000	0.0 – 1000.0 °C Temperature
		0 – 10000	0.0 – 1000.0 °F Temperature
		0 – 1000	0.0 – 100.0 % Efficiency
		0 – 1	0 = Off – 1 = On EGA Status
13	0		<u>Output 3: 20mA Corresponds To</u>
			For this setting, the units will depend on the data source in setting 11.
		0 – 1000	0.0 – 100.0 % O <sub>2</sub>
		0 – 1000	0.0 – 100.0 % CO <sub>2</sub>
		0 - 10000	0 – 10000 ppm CO
		0 - 10000	0 – 10000 ppm NO
		0 - 10000	0 – 10000 ppm NO <sub>2</sub>
		0 - 10000	0 – 10000 ppm SO <sub>2</sub>
		0 – 10000	0.0 – 1000.0 °C Temperature
		0 – 10000	0.0 – 1000.0 °F Temperature
		0 – 1000	0.0 – 100.0 % Efficiency
		0 – 1	0 = Off – 1 = On EGA Status
14	-	-	Unused
15	-	-	Unused

Setting	Default	Range	Description
16	0		<u>Output 4: Data Source</u>
		0	Oxygen Concentration
		1	Carbon Dioxide Concentration
		2	Carbon Monoxide Concentration
		3	Nitric Oxide Concentration
		4	Nitrogen Dioxide Concentration
		5	Sulphur Dioxide Concentration
		6	Ambient Temperature
		7	Exhaust Temperature
		8	Efficiency
		9	EGA Status
17	0		<u>Output 4: 4mA Corresponds To</u>
			For this setting, the units will depend on the data source in setting 16.
		0 – 1000	0.0 – 100.0 % O <sub>2</sub>
		0 – 1000	0.0 – 100.0 % CO <sub>2</sub>
		0 - 10000	0 – 10000 ppm CO
		0 - 10000	0 – 10000 ppm NO
		0 - 10000	0 – 10000 ppm NO <sub>2</sub>
		0 - 10000	0 – 10000 ppm SO <sub>2</sub>
		0 – 10000	0.0 – 1000.0 °C Temperature
		0 – 10000	0.0 – 1000.0 °F Temperature
		0 – 1000	0.0 – 100.0 % Efficiency
		0 – 1	0 = Off – 1 = On EGA Status
18	0		<u>Output 4: 20mA Corresponds To</u>
			For this setting, the units will depend on the data source in setting 16.
		0 – 1000	0.0 – 100.0 % O <sub>2</sub>
		0 – 1000	0.0 – 100.0 % CO <sub>2</sub>
		0 - 10000	0 – 10000 ppm CO
		0 - 10000	0 – 10000 ppm NO
		0 - 10000	0 – 10000 ppm NO <sub>2</sub>
		0 - 10000	0 – 10000 ppm SO <sub>2</sub>
		0 – 10000	0.0 – 1000.0 °C Temperature
		0 – 10000	0.0 – 1000.0 °F Temperature
		0 – 1000	0.0 – 100.0 % Efficiency
		0 – 1	0 = Off – 1 = On EGA Status
19	-	-	Unused
20	-	-	Unused

Setting	Default	Range	Description
21	0		<u>Output 5: Data Source</u>
		0	Oxygen Concentration
		1	Carbon Dioxide Concentration
		2	Carbon Monoxide Concentration
		3	Nitric Oxide Concentration
		4	Nitrogen Dioxide Concentration
		5	Sulphur Dioxide Concentration
		6	Ambient Temperature
		7	Exhaust Temperature
		8	Efficiency
		9	EGA Status
22	0		<u>Output 5: 4mA Corresponds To</u>
			For this setting, the units will depend on the data source in setting 21.
		0 – 1000	0.0 – 100.0 % O <sub>2</sub>
		0 – 1000	0.0 – 100.0 % CO <sub>2</sub>
		0 - 10000	0 – 10000 ppm CO
		0 - 10000	0 – 10000 ppm NO
		0 - 10000	0 – 10000 ppm NO <sub>2</sub>
		0 - 10000	0 – 10000 ppm SO <sub>2</sub>
		0 – 10000	0.0 – 1000.0 °C Temperature
		0 – 10000	0.0 – 1000.0 °F Temperature
		0 – 1000	0.0 – 100.0 % Efficiency
		0 – 1	0 = Off – 1 = On EGA Status
23	0		<u>Output 5: 20mA Corresponds To</u>
			For this setting, the units will depend on the data source in setting 21.
		0 – 1000	0.0 – 100.0 % O <sub>2</sub>
		0 – 1000	0.0 – 100.0 % CO <sub>2</sub>
		0 - 10000	0 – 10000 ppm CO
		0 - 10000	0 – 10000 ppm NO
		0 - 10000	0 – 10000 ppm NO <sub>2</sub>
		0 - 10000	0 – 10000 ppm SO <sub>2</sub>
		0 – 10000	0.0 – 1000.0 °C Temperature
		0 – 10000	0.0 – 1000.0 °F Temperature
		0 – 1000	0.0 – 100.0 % Efficiency
		0 – 1	0 = Off – 1 = On EGA Status
24	-	-	Unused
25	-	-	Unused

Setting	Default	Range	Description
26	0		<u>Output 6: Data Source</u>
		0	Oxygen Concentration
		1	Carbon Dioxide Concentration
		2	Carbon Monoxide Concentration
		3	Nitric Oxide Concentration
		4	Nitrogen Dioxide Concentration
		5	Sulphur Dioxide Concentration
		6	Ambient Temperature
		7	Exhaust Temperature
		8	Efficiency
		9	EGA Status
27	0		<u>Output 6: 4mA Corresponds To</u>
			For this setting, the units will depend on the data source in setting 26.
		0 – 1000	0.0 – 100.0 % O <sub>2</sub>
		0 – 1000	0.0 – 100.0 % CO <sub>2</sub>
		0 - 10000	0 – 10000 ppm CO
		0 - 10000	0 – 10000 ppm NO
		0 - 10000	0 – 10000 ppm NO <sub>2</sub>
		0 - 10000	0 – 10000 ppm SO <sub>2</sub>
		0 – 10000	0.0 – 1000.0 °C Temperature
		0 – 10000	0.0 – 1000.0 °F Temperature
		0 – 1000	0.0 – 100.0 % Efficiency
		0 – 1	0 = Off – 1 = On EGA Status
28	0		<u>Output 6: 20mA Corresponds To</u>
			For this setting, the units will depend on the data source in setting 26.
		0 – 1000	0.0 – 100.0 % O <sub>2</sub>
		0 – 1000	0.0 – 100.0 % CO <sub>2</sub>
		0 - 10000	0 – 10000 ppm CO
		0 - 10000	0 – 10000 ppm NO
		0 - 10000	0 – 10000 ppm NO <sub>2</sub>
		0 - 10000	0 – 10000 ppm SO <sub>2</sub>
		0 – 10000	0.0 – 1000.0 °C Temperature
		0 – 10000	0.0 – 1000.0 °F Temperature
		0 – 1000	0.0 – 100.0 % Efficiency
		0 – 1	0 = Off – 1 = On EGA Status
29	-	-	Unused
30	-	-	Unused

## 2.3 Commissioning MM with EGA

Commissioning with the EGA is an extension to commissioning with the MM and is required if the trim function is to be used. The factory trained technician must be completely familiar with the commissioning of the MM unit before commissioning with the EGA. For the full commissioning procedure, please refer to the Mk8 MM Installation and Commissioning Guide and Mini Mk8 MM Installation and Commissioning Guide.

The commissioning procedure as described must be strictly adhered to. Anybody commissioning an MM/EGA system must have an adequate understanding of combustion plants and be officially certified by Autoflame Engineering.

**In the wrong hands, hazardous conditions could be made to exist that could lead to product damage, critical injury or death.**

The fundamental idea of the system is to set a fuel valve position and then set a corresponding air valve position. Care must be taken when adjusting the fuel and air positions so as not to create any unstable or dangerous combustion conditions, e.g. moving the fuel valve to the open position without increasing the air valve correspondingly.

Commissioning a system with an EGA does not require a combustion monitor as the EGA performs all normal exhaust gas measurements. When burning oil, a smoke detection device should be used, to check that the smoke generated is within government guidelines.

Ideally, to implement commissioning as quickly as possible arrange for a substantial load on the boiler. The commissioning procedure can be interrupted due to excess temperature or pressure, causing the burner to turn off. In these instances the commissioning data accumulated so far is not lost. When the burner is called back on, the system starts up automatically and commissioning can proceed from where it left off.

Once the burner has been fired the maximum fuel position is entered first then descending fuel positions are entered consecutively until finally a minimum fuel position is entered. The CH1 and CH2 positions must always be less than the ones previously entered. However with the remaining channels it is possible to move the position above or below the previously entered points. This is important if these channels are used to control FGR (Flue Gas Recirculation) or atomisation of oil.

On a newly installed system the following procedures should be carried out as listed:

1. Check all interconnecting wiring between the MM and external components are correct.
2. Set the MM Settings and EGA Settings, see sections 2.1.1 and 2.2, respectively.
3. Set up positioning motors.
4. Programme fuel/air positions.

**Note: For the safety and operational checks, and the full commissioning procedure please refer to the Mk8 MM Installation and Commissioning Guide and the Mini Mk8 MM Installation and Commissioning Guide.**

On the Mk8 MM and Mini Mk8 MM, it is possible to commission the burner with option 12 set to no EGA or monitoring only, then add EGA trim later by setting option 12 to 2 or 3 and adding the trim positions in single point change. Once commissioning is complete and all points are entered, the trim is then set in Single Point Change. Ensure that option 12 is now set to trim. Once in single point change you will then be able to activate the trim by pressing the 'trim' button when on a particular point.



## 2.4 Calibration Schedule

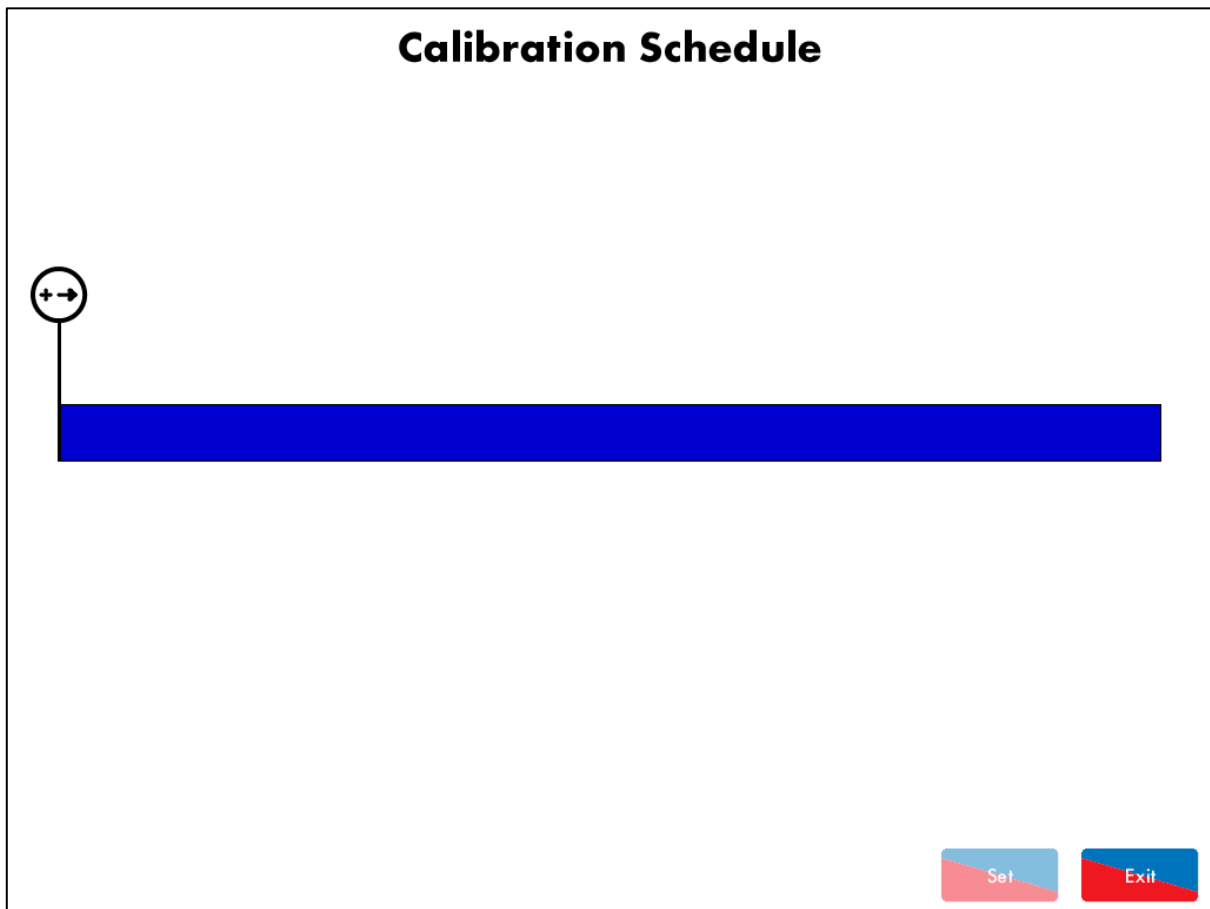



Figure 2.4.i Calibration Schedule (clear)

Press  in the Commission Menu screen shown in Figure 2.2.iii to access the Calibration Schedule screen. Alternatively, press  in the System Configuration screen and enter the Online Changes password.

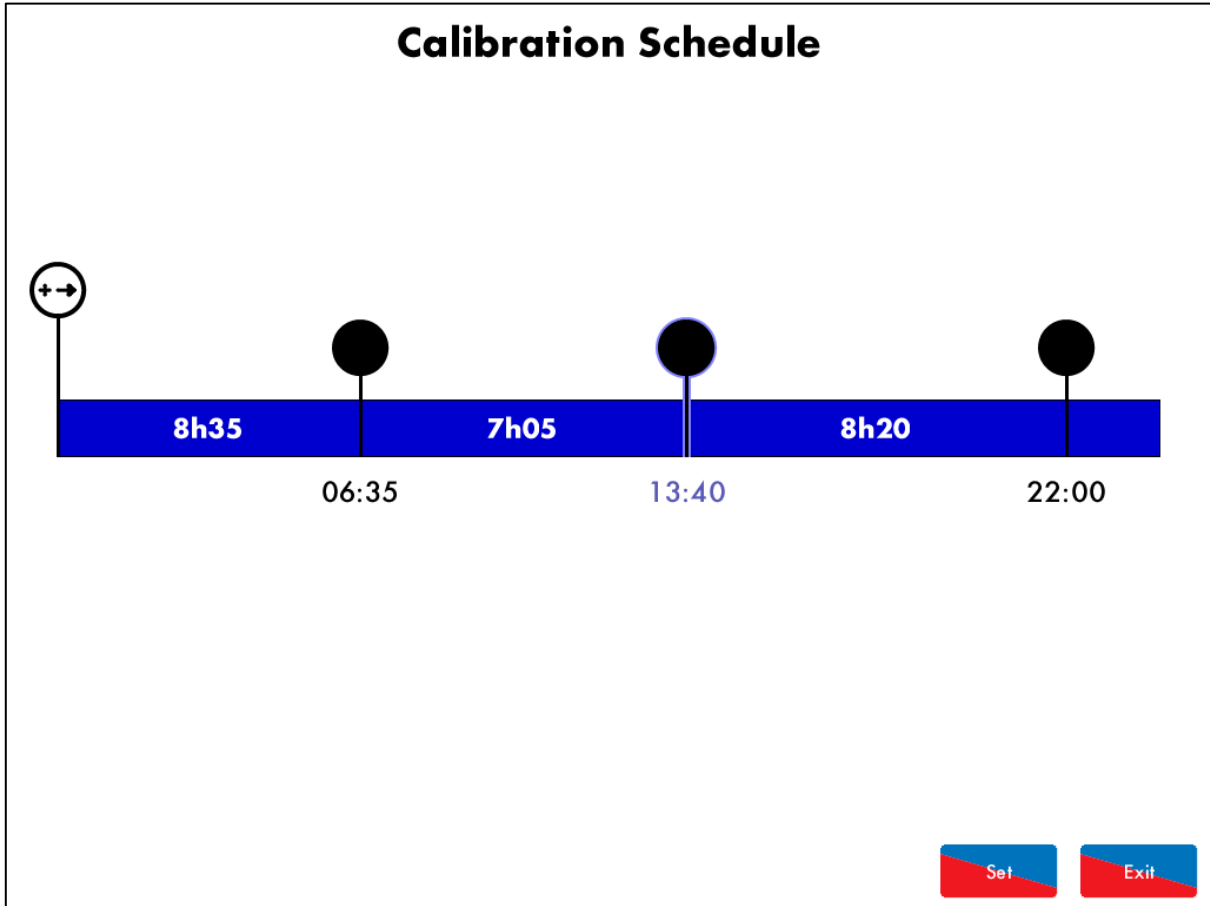







Figure 2.4.ii Calibration Schedule

Press on  to add an air calibration time, and drag this circle to the left or right to adjust to the time. The air calibrations can be scheduled at 5 minute intervals, and up to 4 air calibrations can be added over a 24 hour period.

To remove an air calibration press on  and drag the circle up, and then press  to remove this air calibration from the calibration schedule.

Once the air calibrations have been set, press  to save the air calibration schedule, and then press  to leave the calibration schedule screen.

To force an air calibration, either trigger this on the MM, or in the System Configuration screen, see section 3.9.







**Note:** An air calibration schedule must be set for the health life % to display in the Cell Information screen, see section 3.8.

## 2.5 Resetting Data

In the Commission Menu screen shown in Figure 2.2.iii, it is possible to reset data on the EGA.





### 2.5.1 Reset Cells to Factory Calibration

If the cell calibration is not accurate, the cells can be reset to factory calibration.

- Press and hold  for 3 seconds to reset the O<sub>2</sub> cell to factory calibration.
- Press and hold  for 3 seconds to reset the CO<sub>2</sub> cell to factory calibration.
- Press and hold  for 3 seconds to reset the CO cell to factory calibration.
- Press and hold  for 3 seconds to reset the NO cell to factory calibration.
- Press and hold  for 3 seconds to reset the NO<sub>2</sub> cell to factory calibration (if fitted).
- Press and hold  for 3 seconds to reset the SO<sub>2</sub> cell to factory calibration (if fitted).

### 2.5.2 Reset Run Times

When a new cell is fitted on the EGA, the run times and data for the previous data should be reset. Similarly, when a new EGA pump is fitted, the pump run times should also be reset for previous pump.

- Press and hold  for 3 seconds to reset all the exhaust gas and fuel flow data for fuel 1.
- Press and hold  for 3 seconds to reset all the exhaust gas and fuel flow data for fuel 2.
- Press and hold  for 3 seconds to reset all the exhaust gas and fuel flow data for fuel 3.
- Press and hold  for 3 seconds to reset all the exhaust gas and fuel flow data for fuel 4.
- Press and hold  for 3 seconds to reset the EGA pump data.

### 2.5.3 Reset Other Data

If the service interval period set in Commission Mode setting 54 has elapsed, and a service has been completed on the EGA, the service interval can be reset.

- Press and hold  for 3 seconds to reset the service interval period.

If the new calibration drift has been corrected by fitting a new cell or performing an accurate calibration, the calibration drift data can be reset.

- Press and hold  for 3 seconds to reset the calibration drift data.

- Press and hold  for 3 seconds to reset the system log.

- Press and hold  for 3 seconds to reset the fault log.

### 3 SYSTEM CONFIGURATION

#### 3.1 Language

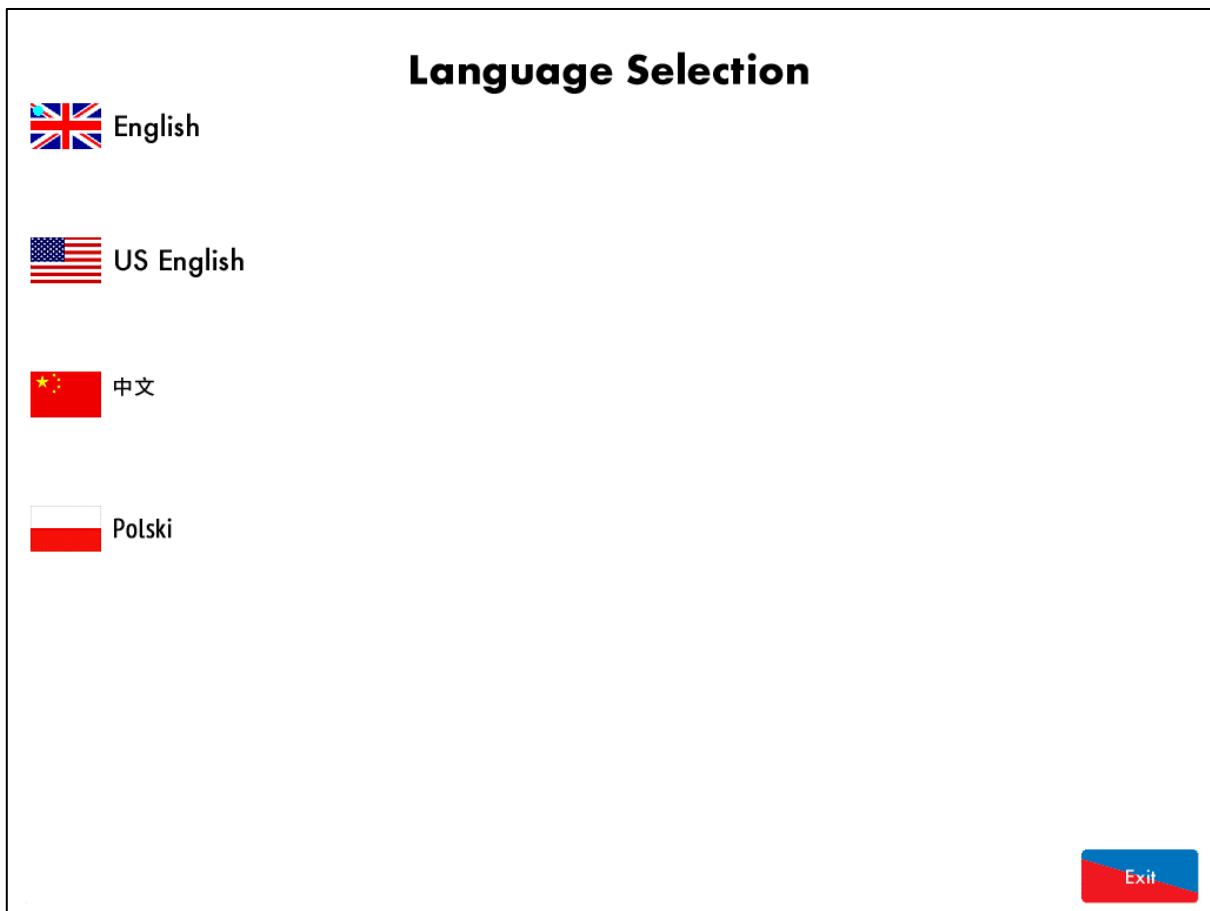



Figure 3.1.i Language Selection

Press  in the System Configuration. Enter the Online Changes password to access the Language Selection screen. Select the desired language and then press  to save the selection and return to the System Configuration screen.

If the language required is not displayed, please contact your local Autoflame representative or Autoflame Sales.

### 3.2 Set Clock

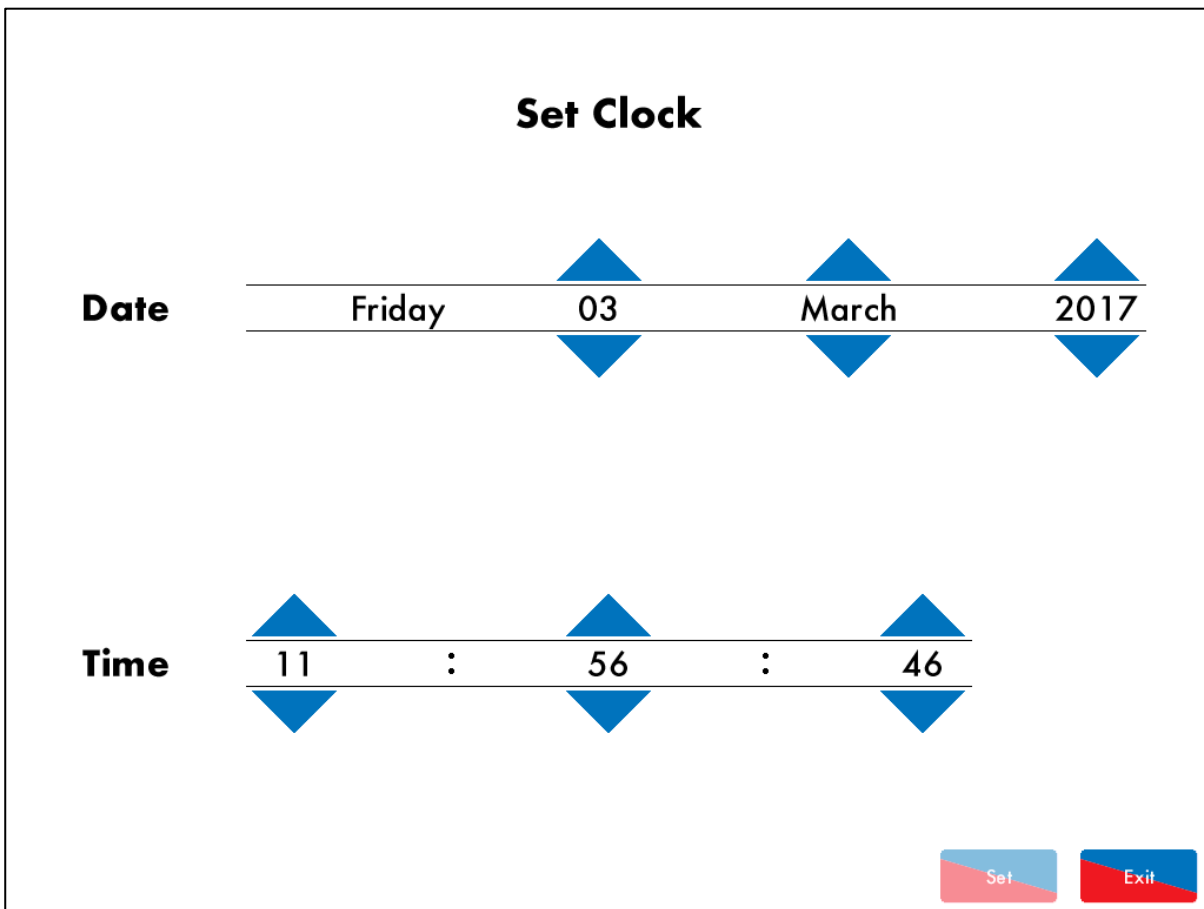



Figure 3.2.i Set Clock

Press  in the System Configuration screen. Enter the Set Clock password (10, 10) to access the Set Clock screen.

Adjust the time and date by using the  and  buttons, and then press  to save the time and then  to go back to the System Configuration screen.

**Note:** Changing the time and date will affect the logged exhaust and fuel flow data, so it is recommended to set the clock when the EGA is installed and then leave it at that time and date setting.

### 3.3 Online Changes

#### 3.3.1 Settings

Online Changes		Value
#	Description	
1	Base: Control Mode	Controlled by MM
2	Base: Communications Id	1
3	Base: Display Units	Metric
4	Base: Efficiency Calculation Method	English
5	Base: Currency Units	GBP
6	Base: Backlight On Time	600 seconds
7	Base: Logo Display Timer	600 seconds
8	Base: Show Advanced Values	Disabled
9	Unused: Unused	0
10	Cells: CO Poison Detection	Enabled
11	Cells: CO Poison Limit	600 ppm
12	Cells: CO Poison Return	200 ppm
13	Cells: SO2 Correction	100%
14	Cells: Minimum NO2 Fraction of NOx (if NO2 cell fitted)	0%
15	Cells: NOx Normalised O2 Value	3.0% O2
16	Cells: NO Fraction of NOx (if NO2 cell not fitted)	94.0%
17	Cells: Standard Temperature	298.0 °K
18	Cells: Standard Pressure	1013.2 mbar (406.8 inWG)
19	Unused: Unused	0

All
Base
Cells
Calibration
Back box
System
Vendor









Figure 3.3.1.i Online Changes – Settings

Press on  in the System Configuration screen. Enter the Online Changes password to access the Online Changes screen for the Commission Mode settings, where some of the settings can be adjusted, see section 2.2.1 on Commission Mode settings.

#### 3.3.2 Fuel Setup

Press  in the System Configuration screen. Enter the Online Changes password to access the Fuel Setup screen where the settings can be adjusted, see section 2.2.2 on Fuel Setup settings.

Once the settings have been adjusted as required, press  to save the settings and go back to the System Configuration screen.

#### 3.3.3 Calibration Schedule

Press  in the System Configuration screen. Enter the Online Changes password to access the Calibration Schedule screen, see section 2.4.

### 3.4 Run Times

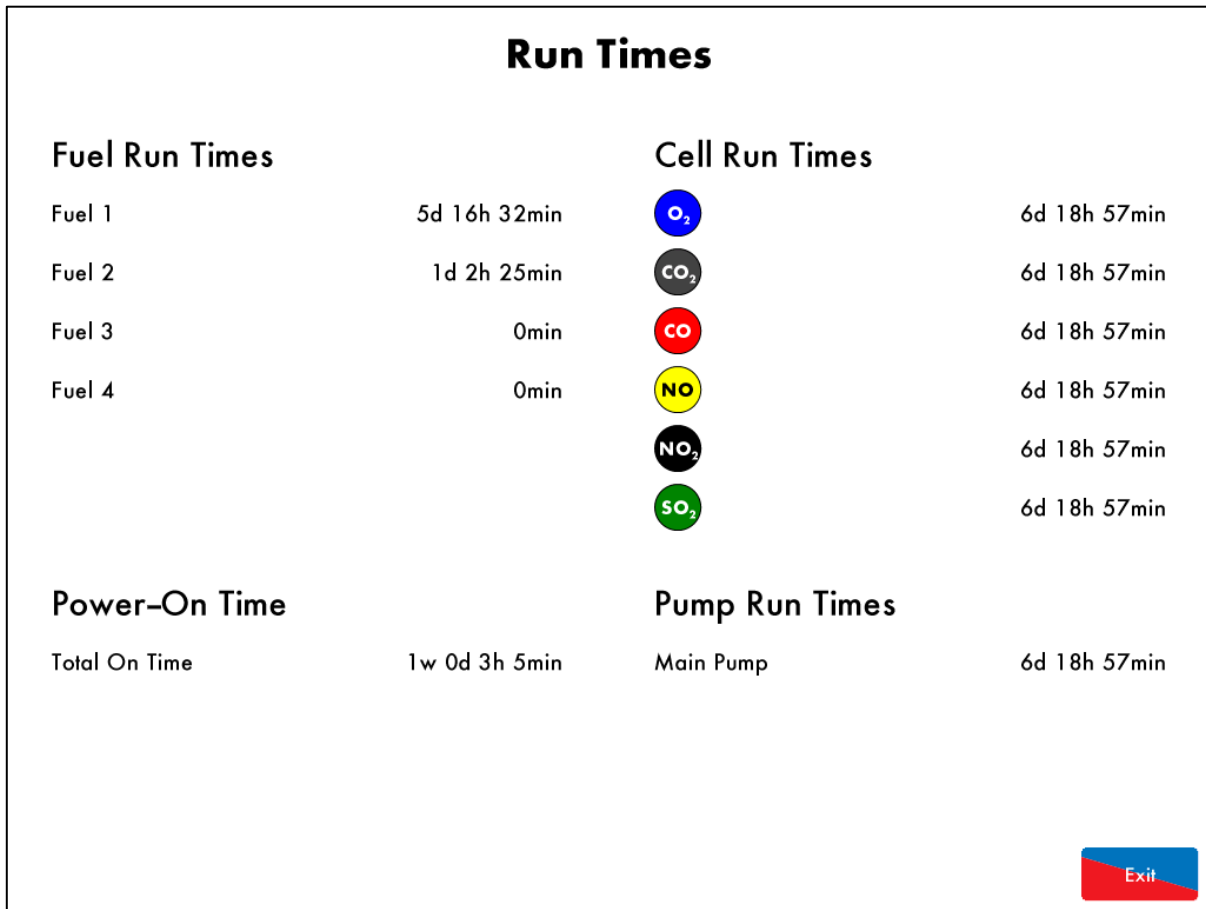



Figure 3.4.i Run Times

Press  in the System Configuration screen to access the Run Times screen. The Run Times screen provides the following information:

- Fuel run times
- Power on time
- Fitted cell run times
- EGA pump run time

Press  to go back to the System Configuration screen.

### 3.5 Diagnostics

Diagnostics		
#	Description	Value
1	EGA: Processor temperature (Now)	42.9°C
2	EGA: Processor temperature (Min)	(Limit 3.0°C) 27.3°C
3	EGA: Processor temperature (Max)	(Limit 140.0°C) 45.3°C
4	EGA: PCB temperature (Now)	26.3°C
5	EGA: PCB temperature (Min)	(Limit 3.0°C) -4.9°C
6	EGA: PCB temperature (Max)	(Limit 40.0°C) 27.0°C
7	Cells: CO2 cell bulb current (Now)	0.562A
8	Cells: CO2 cell bulb current (Min)	0.000A
9	Cells: CO2 cell bulb current (Max)	0.763A
10	EGA: Chiller Current	0.194A
11	Comms: Messages sent to MM per minute	58
12	Comms: Messages sent to DTI per minute	20
13	Cells: O2 Cell raw reading	-629
14	Cells: CO2 Cell raw reading	8977
15	Cells: CO Cell raw reading	17
16	Cells: NO Cell raw reading	151
17	Cells: NO2 Cell raw reading	-5
18	Cells: SO2 Cell raw reading	103
19	Cells: CO2 Cell temperature	29.9°C
20	EGA: Fan frequency	86.0Hz









Figure 3.5.i Diagnostics

Press  in the System Configuration screen to access the Diagnostics screen. The Diagnostics screen shows the real-time values of the EGA's environmental conditions, as well as the minimum and maximum values which have been detected in its entire operating period. Press on the tabs to view the following information:

- Processor temperature
- PCB temperature
- Chiller current
- Fan frequency
- CO<sub>2</sub> bulb current
- O<sub>2</sub> cell raw reading
- CO<sub>2</sub> cell raw reading
- CO cell raw reading
- NO cell raw reading
- NO<sub>2</sub> cell raw reading
- SO<sub>2</sub> cell raw reading
- CO<sub>2</sub> cell temperature
- Messages sent to MM per minute
- Messages sent to DTI per minute



### 3.6 System Log

System Log	Detail	Occurred
1. Fuel Selection	Fuel 1 Selected	15 Feb 17 12:43
2. EGA Started		15 Feb 17 12:43
3. Fuel Selection	Fuel 1 Selected	15 Feb 17 12:30
4. EGA Started		15 Feb 17 12:30
5. Fuel Setup 32 Changed	Costing Units (From 0 To 2)	10 Feb 17 16:54
6. Fuel Setup 31 Changed	Fuel Type (From 0 To 1)	10 Feb 17 16:54
7. Fuel Setup 22 Changed	Costing Units (From 0 To 2)	10 Feb 17 16:54
8. Fuel Setup 21 Changed	Fuel Type (From 0 To 1)	10 Feb 17 16:54
9. Fuel Setup 12 Changed	Costing Units (From 3 To 2)	10 Feb 17 16:54
10. Fuel Setup 11 Changed	Fuel Type (From 6 To 1)	10 Feb 17 16:54
11. Fuel Setup 3 Changed	Cost Per Unit (From 1000 To 1750)	10 Feb 17 16:50
12. Fuel Selection	Fuel 1 Selected	10 Feb 17 14:56
13. EGA Started		10 Feb 17 14:56
14. Fuel Selection	Fuel 1 Selected	7 Feb 17 12:27
15. Fuel Selection	No Fuel Selected	7 Feb 17 12:27
16. Fuel Selection	Fuel 1 Selected	6 Feb 17 10:36
17. EGA Started		6 Feb 17 10:36
18. Fuel Selection	Fuel 1 Selected	2 Feb 17 12:29
19. EGA Started		2 Feb 17 12:29
20. Calibration Schedule Change		2 Feb 17 12:01
21. Setting 21 Changed	Air Calibration Time (From 20 To 360)	31 Jan 17 09:57
22. Setting 40 Changed	MM Comms Mode (From 1 To 0)	31 Jan 17 09:51

All
Faults
Config
Service
Operation

Figure 3.6.i System Log

Press in the System Configuration screen to access the System Log. The System stores 1000 entries of changes or any faults that have occurred, including:

- Errors and warnings
- Settings which have been changed
- Service intervals
- Fuel selection
- EGA turned on/off

### 3.7 Manual

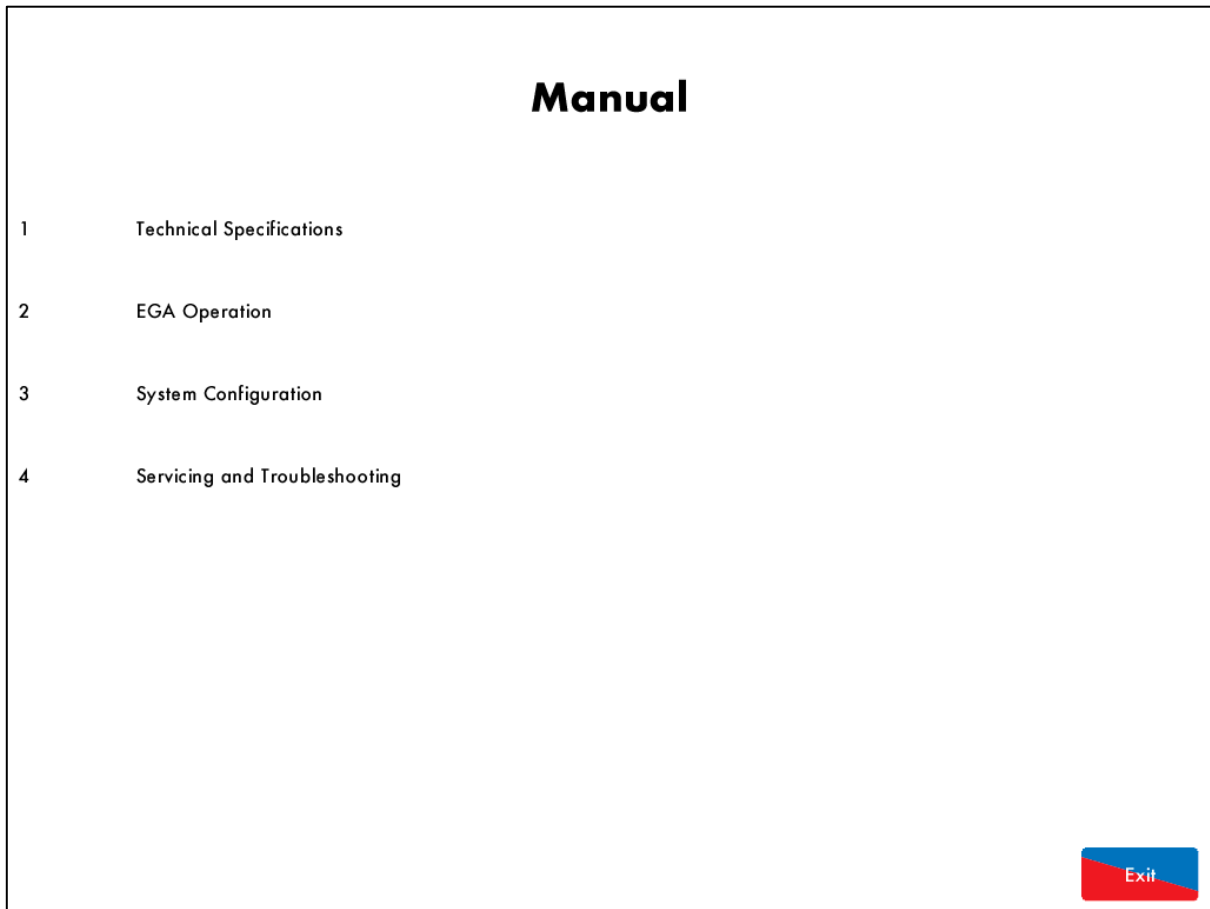



Figure 3.7.i Manual

Press  in the System Configuration screen to access the Manual screen.

### 3.8 Cell Information

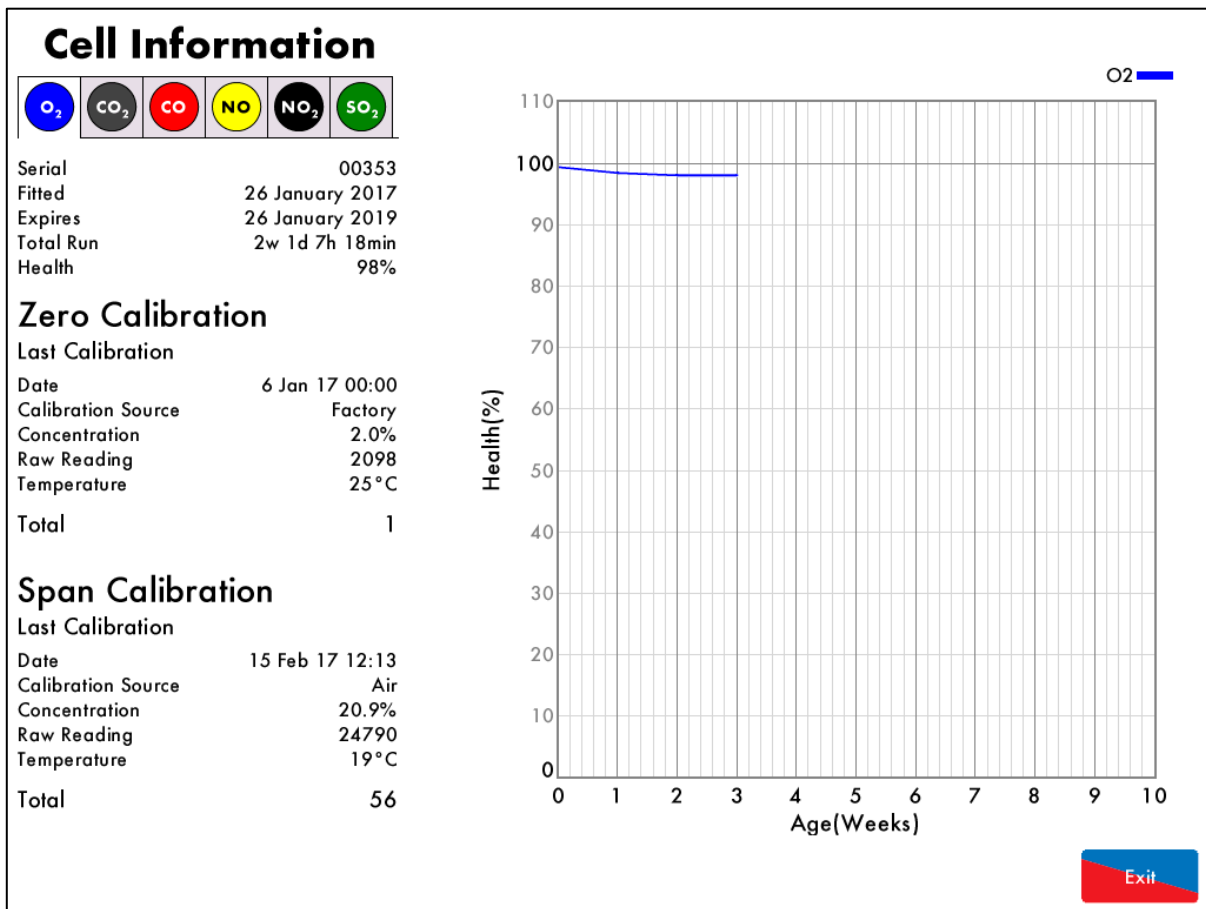



Figure 3.8.i Cell Information Screen

Press  in the System Configuration screen to access the Cell Information screens. Press on the tabs for information on each cell fitted, including:

- Cell serial number
- Date cell was fitted
- Cell expiry date
- Total run times
- Health
- Last zero calibration date, source, concentration, raw reading, temperature, and total number of zero calibrations
- Last span calibration date, source, concentration, raw reading, temperature and total number of span calibrations (and pressure of span calibration for CO<sub>2</sub> cell)

**Note:** The health % of the cell will only show in the air calibration has been set, see section 2.4.

### 3.8.1 O<sub>2</sub> Cell Characteristics

This electrochemical cell is used for the detection of oxygen covering a concentration range of 0 to 20.95%. Due to the construction of the cell they offer a long life and a high resistance, even when used with high sulphur content fuels, therefore making it capable of analysis when firing heavy or light fuel oil.

The oxygen cell incorporates a lead oxygen cell with a Lead anode and a Gold cathode, using a specific acid electrolyte. Oxygen molecules which diffuse through a non-porous Teflon membrane into the electromechanical cell are reduced at the Gold electrode. The current flow between the electrodes is proportional to the oxygen concentration in the flue gases measured. The O<sub>2</sub> readings are not influenced from CO, H<sub>2</sub>, S, NOX and SOX so there is no cross-sensitivity.



Figure 3.8.1.i O<sub>2</sub> Cell

#### Operation Ranges:

Detection Range	0 – 23% O <sub>2</sub>
Accuracy	± 0.3 % Vol O <sub>2</sub>
Operating Temperature	5°C to 40°C (41°F to 104°F)
Shelf Life	6 months from date of dispatch
Long Term Output Drift	< 1% signal/month typically < 10% over operating life

As the O<sub>2</sub>, CO, NO, SO<sub>2</sub> and NO<sub>2</sub> cells all have a 6 month shelf-life, it may be better to request for the cells to be shipped when the EGA is being installed on site. Depending on the conditions and environment the EGA is in, the cell's life expectancy can go up to 2 years. It is important to replace the cells when the EGA flags this up on the screen. Cells will need to be changed every 9 to 12 months firing on gas, and 6 to 9 months firing on oil.

Please see section 2.5.2 on resetting previous cell run times after changing the cell.

### 3.8.2 CO, NO, NO<sub>2</sub> and SO<sub>2</sub> Cell Characteristics

The CO, NO, NO<sub>2</sub> and SO<sub>2</sub> electromechanical cells which are specifically managed by the calibration philosophy within the Mk8 EGA unit. The accuracy of these cells is within limits of  $\pm 5\%$  at 100ppm. From experience we would expect to see a drift of  $\pm 10$ ppm per annum without calibration. In our view, this drift would not be detrimental to the operation or application of the EGA.

The life of the cells depends on the concentration of the gases measured over time. In order to optimise the life of the CO cell, the electronics will detect when the signal level from the cell reaches or exceeds 500ppm and will stop sampling and purge the system. The sample gas flow to these cells is restored once the O<sub>2</sub> and CO<sub>2</sub> readings are restored to a level within the pre-programmed limits.



Figure 3.8.2.i CO, NO, SO<sub>2</sub> and NO<sub>2</sub> Cells

	Gas (range)	Fuel Oil (range)	Resolution at 20°C	Repeatability	Shelf Life
CO	0-1000ppm	Optional	1ppm	1% of signal	6months from dispatch
NO	0-500ppm	Optional	1ppm	2% of signal	6months from dispatch
SO <sub>2</sub>	Optional	0-1000ppm	1ppm	1% of signal	6months from dispatch
NO <sub>2</sub>	Optional	0-200ppm	0.5ppm	2% of signal	6months from dispatch

Please see section 2.5.2 on resetting previous cell run times after changing the cell.

**Note:** The NO<sub>2</sub> and SO<sub>2</sub> values will display on the EGA sampling screen as calculated values if the NO<sub>2</sub> and SO<sub>2</sub> cells are not fitted.

### 3.8.3 CO2 Sensor

The CO<sub>2</sub> sensor is manufactured in-house at Autoflame; the technology used is non-dispersive Infra-red. This sensor has no moving parts and is not an electrochemical cell. The accuracy of the reading is  $\pm 0.3\%$  of the reading. The cross-sensitivity is virtually zero to other gases due to the method of calibration within the EGA unit. The lifetime is usually no less than two years of gas firing. The lifetime on oil firing is dependent on the Sulphur content of the fuel.

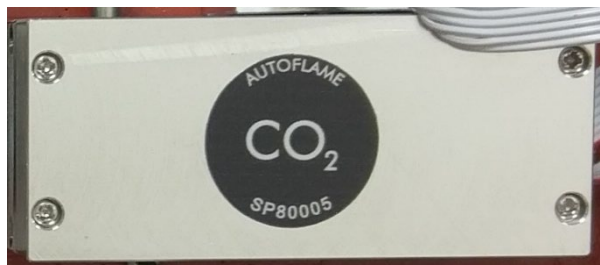



Figure 3.8.3.i CO<sub>2</sub> Cell

Measurement Range: 0-20%  
Shelf-Life: 12months from dispatch  
Accuracy of reading: 0.3%

## 3.9 Calibrate Now

To force the EGA into an air calibration, this can be done by either trigger this action through the EGA screen on the MM, or by pressing and holding  for 3 seconds in the System Configuration screen.

## 4 EGA OPERATION

### 4.1 Sampling Screen Icons

Pressing on the components on the EGA sampling screen will give access to the relevant information screens.

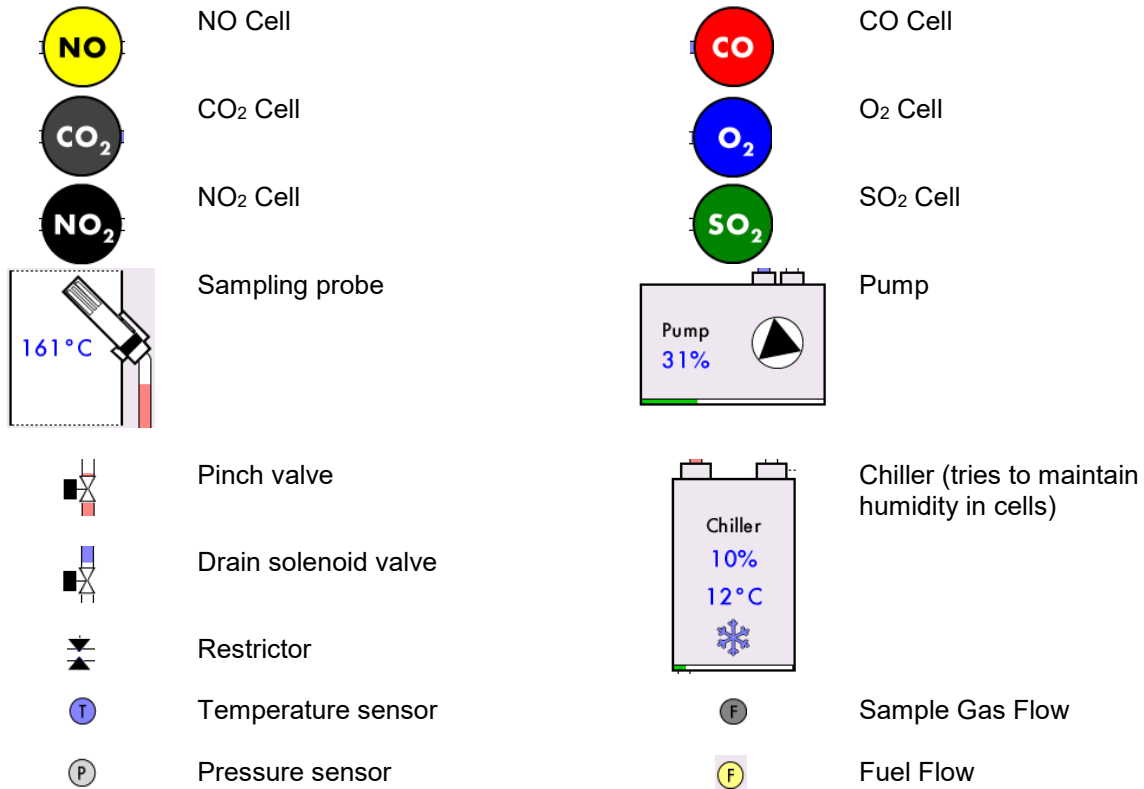

**Note:** The standard cells that are included in the EGA are NO, CO, CO<sub>2</sub>, and O<sub>2</sub>. Optional cells are SO<sub>2</sub> and NO<sub>2</sub>, and they must be fitted at the factory. If the SO<sub>2</sub> and NO<sub>2</sub> cells are not fitted, then the EGA will calculate these values based on the exhaust gases and fuel composition.

### 4.1.1 Temperature

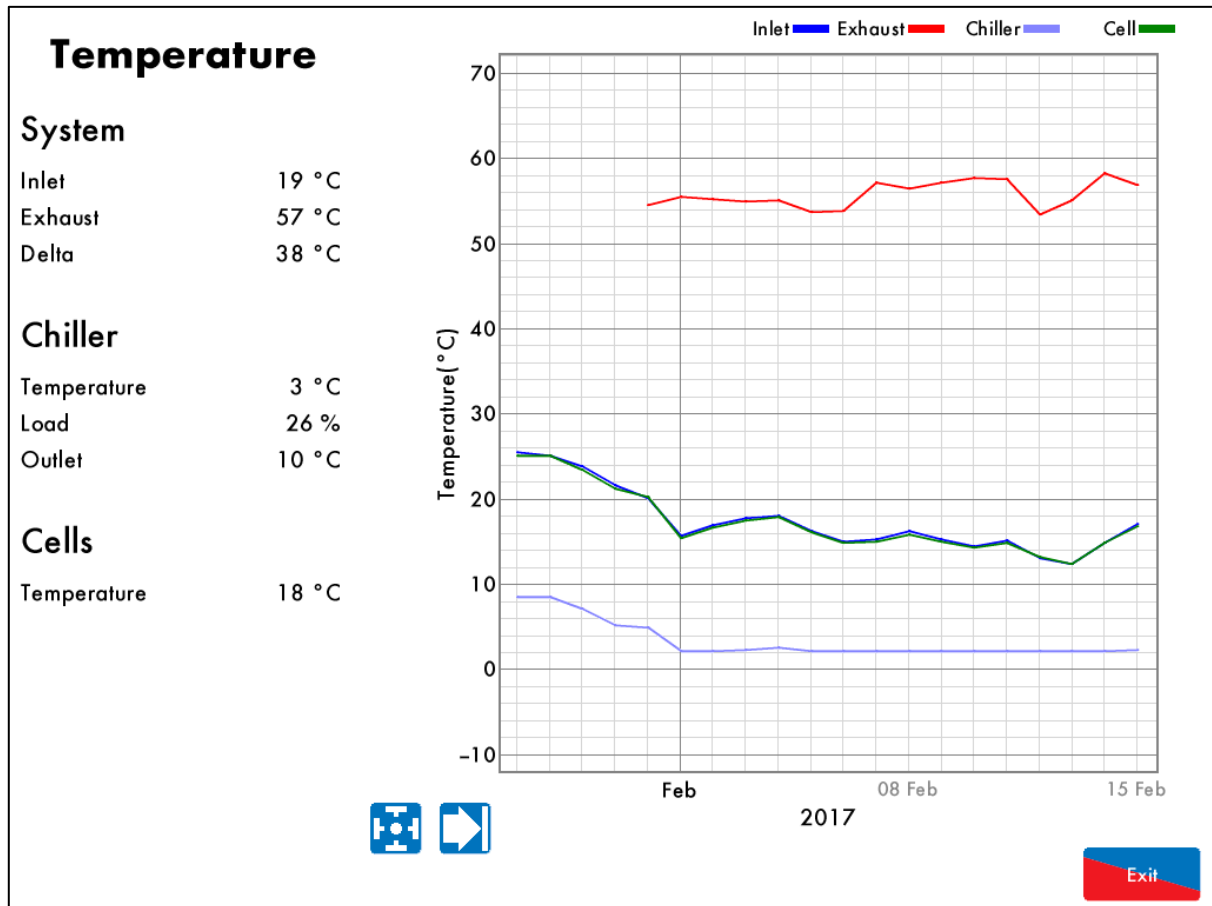

Figure 4.1.1.i Temperature screen on the EGA

Press on either the sampling probe, chiller or temperature sensors on the sampling screen to access the Temperature screen which provides information on:

- Current inlet air temperature
- Current exhaust gas temperature
- Delta temperature
- Chiller temperature
- Chiller load %
- Chiller outlet temperature
- Cells temperature
- Ambient temperature (it is shown separately from the inlet temperature if a pre-heated sensor is enabled, see section 1.7.4)

This data is logged for 3 years on the EGA. Use the  buttons to change the timescale of the data displayed, and press and drag on the axis to zoom in/out of the graph.

This data can be downloaded from the EGA and exporting into an Excel spreadsheet, please refer to the PC Software Guide for more information.



4.1.2 Emissions

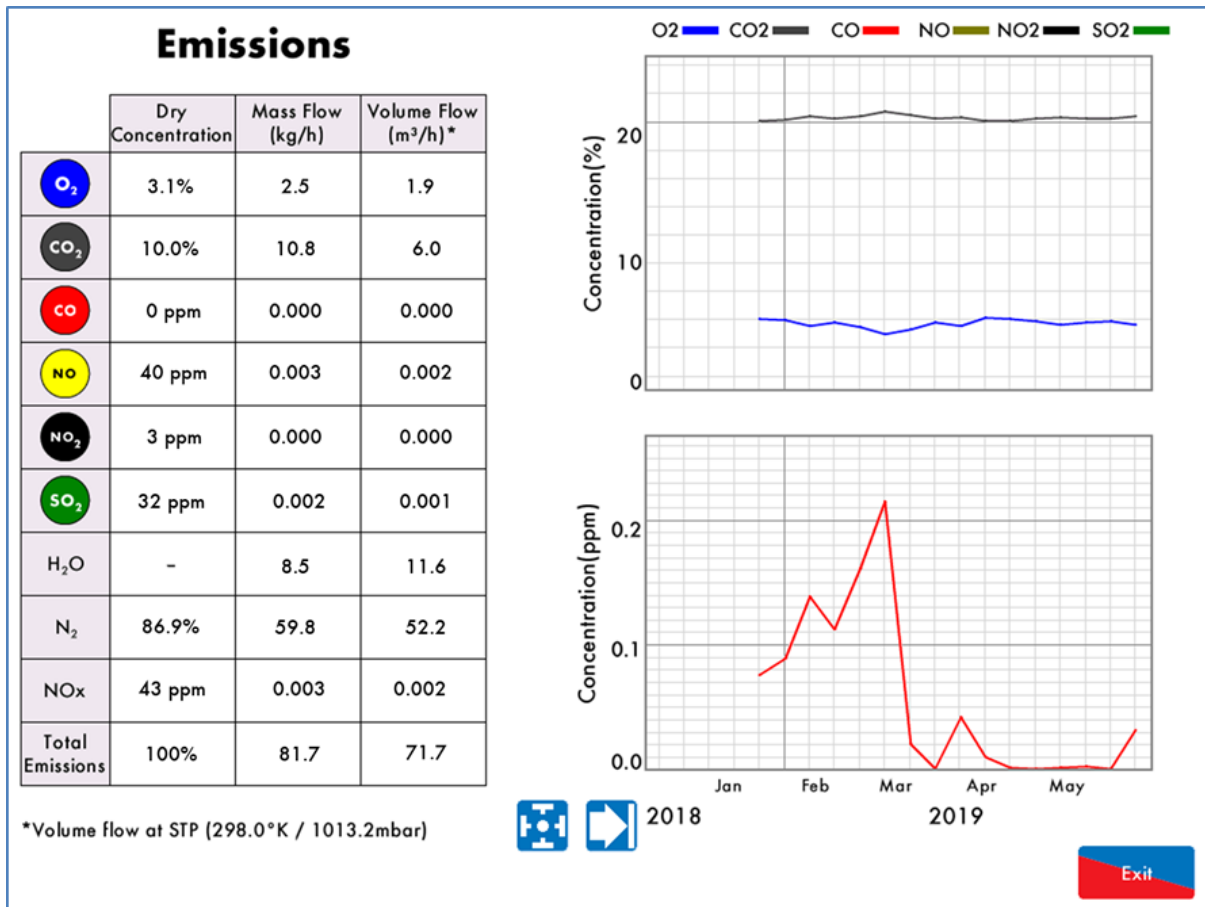

Figure 4.1.2.i Emissions

Press on any of the cells in the sampling screen to access the Emissions screen, which provides the dry volume concentration, mass flow and volume flow for the O<sub>2</sub>, CO<sub>2</sub>, CO, NO, NO<sub>2</sub>, SO<sub>2</sub>, H<sub>2</sub>O, and N<sub>2</sub> emissions in the stack. If NO<sub>2</sub> and SO<sub>2</sub> cells are not fitted, these values are calculated by the EGA. The H<sub>2</sub>O is also calculated within the EGA.

The volume flow is derived from the mass flow, based on the standard temperature and pressure set in Commission Mode settings 17 and 18.

This data is logged for 3 years on the EGA. Use the   buttons to change the timescale of the data displayed, and press and drag on the axis to zoom in/out of the graph.

This data can be downloaded from the EGA and exporting into an Excel spreadsheet, please refer to the PC Software Guide for more information.

### 4.1.3 Pressure

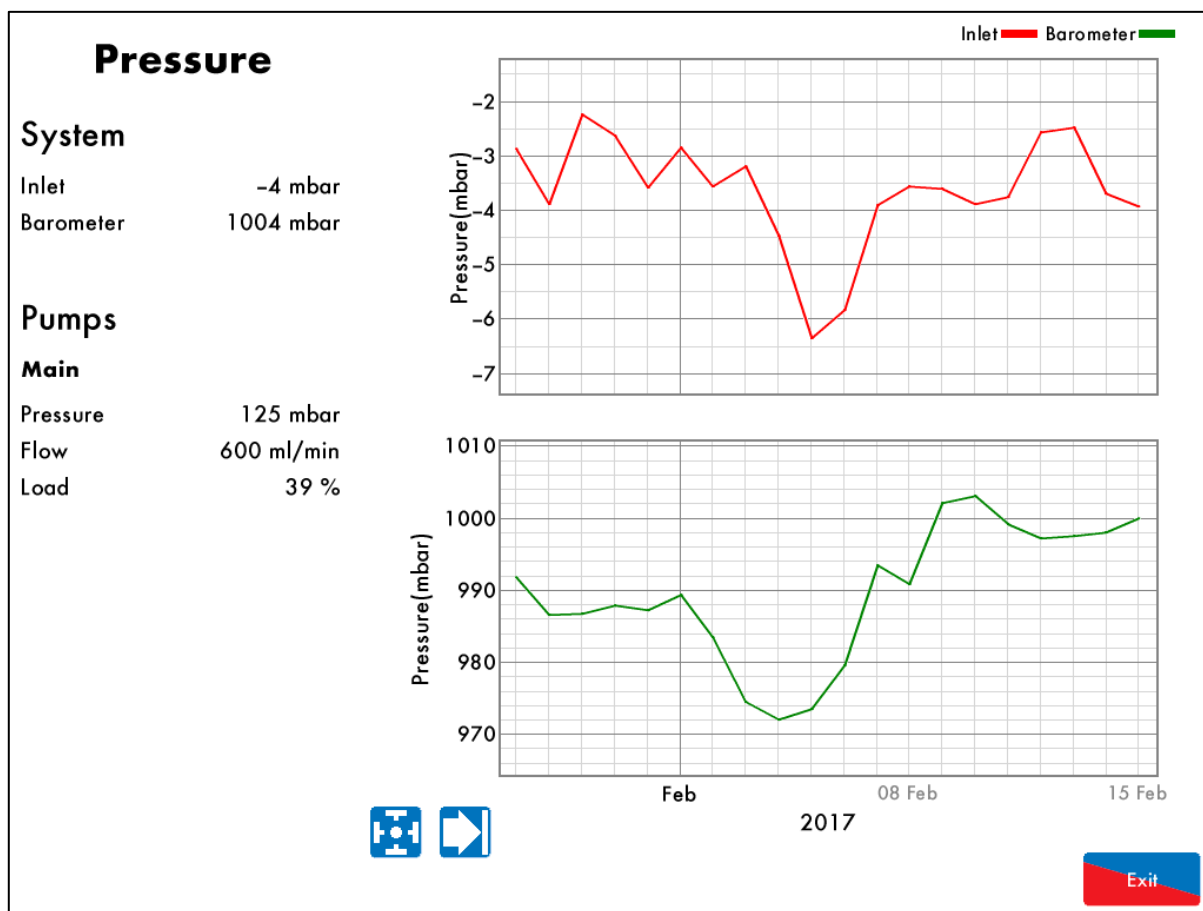



Figure 4.1.3.i Pressure

Press on the pump or the pressures sensors in the sampling screen to access the Pressure screen which gives information on:

- Inlet pressure
- Barometric pressure (in sampling line)
- Pump pressure
- Sample flow
- Pump load %

This data is logged for 3 years on the EGA. Use the   buttons to change the timescale of the data displayed, and press and drag on the axis to zoom in/out of the graph.

This data can be downloaded from the EGA and exporting into an Excel spreadsheet, please refer to the PC Software Guide for more information.

#### 4.1.4 Fuel Flow

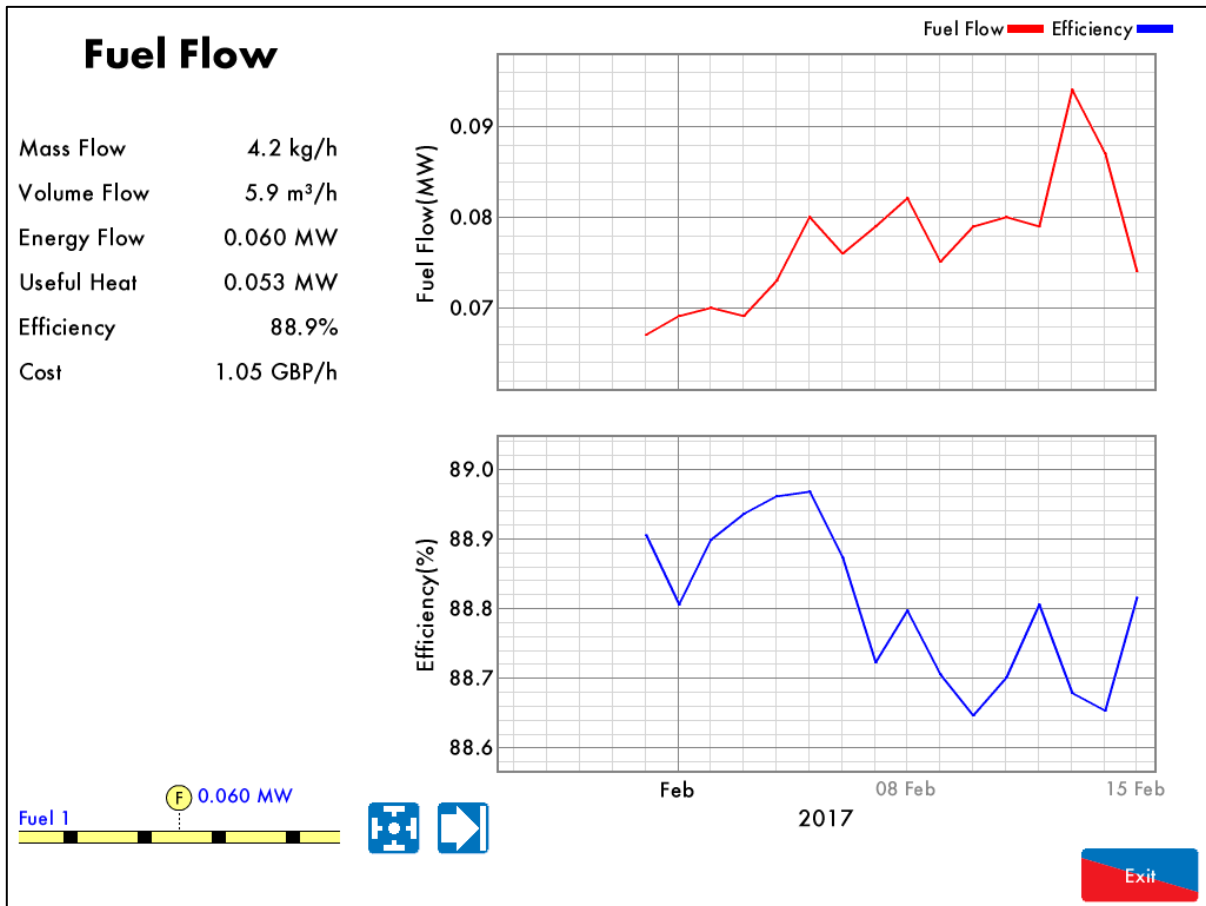

Figure 4.1.4.i Fuel Flow

Press on the fuel flow pipe in the sampling screen to access the fuel flow screen, which provides information on the current fuel being fired:

- Mass flow rate
- Volume flow rate
- Energy flow
- Useful heat
- Combustion efficiency
- Fuel cost per hour

The fuel costs and units are set in the Fuel Setup settings, see section 2.2.2. The currency is set in Commission Mode setting 5.

The combustion efficiency is calculated in the EGA, and can be set as English or European, see Commission Mode setting 4.

This data is logged for 3 years on the EGA. Use the   buttons to change the timescale of the data displayed, and press and drag on the axis to zoom in/out of the graph.

This data can be downloaded from the EGA and exporting into an Excel spreadsheet, please refer to the PC Software Guide for more information.



## 4.2 EGA Overview

### 4.2.1 Features and Benefits

The Exhaust Gas Analyser (EGA) monitors the emissions in the flue produced from the burner/boiler system. The EGA can improve combustion, increase efficiency, reduce fuel consumption and improve safety through its 3-parameter trim function and combustion safety limits.

1. Stand-Alone: When in stand-alone mode, the EGA can be used without a Micro-Modulation (MM) module to monitor the combustion gases. The MM trim function and the combustion safety limits are not activated in this stand-alone mode of operation.
2. With MM: When interfaced with an MM, the EGA can monitor emissions or the 3-parameter combustion trim and safety limits can be activated. The emissions levels are monitored by the EGA and the MM makes small adjustments to the air damper to trim the online exhaust gas data back to the commissioned values.

The main benefits of the EGA include the ability to monitor the exhaust gases and bring them to the safe commissioned levels. Setting the combustion limits on the MM in conjunction with the EGA prevents unsafe combustion scenarios, reducing the fuel consumed in bad combustion. The exhaust and fuel data is logged for 3 years on the EGA and DTI, and can also be downloaded from the EGA.

### 4.2.2 System Operation

The EGA samples the combustion gases via the stack mounted sampling probe (purchased separately from the analyser). The exhaust gases are drawn from the stack by a pump mounted internally within the analyser. Only the supplied sample tubing should be used between the sampling probe and analyser. The internal diameter of the sampling tube is 3mm; if a large diameter tubing is used the sample gas remains resident in the tubing for a longer period. The EGA will then not be able to respond in time to combustion changes, resulting in incorrect operation of the trim function.

Once the exhaust gases have entered the EGA the chiller block reduces their temperature and dries the sample to remove the condensation from the gases prior to entering the cells. The condensate accumulated in the chiller unit is drained every 4 minutes when running, and every 10 minutes when the EGA is in idle mode, automatically through the drain solenoid.

The exhaust gas is then filtered through the dry filter, which is a fine filter used to remove any dust particles carried over from the cooling process. If the burner is firing on heavy or dirty oil, an external particulate filter must be used to remove the excess dirt particles. On leaving the filter, the exhaust gas pressure is checked again to ensure that a vacuum is maintained prior to entering the pump and on exiting the pump, the pressure produced by the pump is checked. Both these pressure sensors modulate the flow rate of the sample into the EGA for consistent operation. Once the exhaust gases have been conditioned, they are ready for an accurate sampling by the cells. After the gases have been sampled by all the cells, the remaining sample is pumped out of the EGA from the clear tubing at the bottom of the EGA casing.

**Note:** The EGA needs to vent to atmosphere via the drain solenoid on the bottom; this is also where the EGA performs its air calibrations. Care should be taken to ensure the outlet is not restricted nor that contamination from exhaust gas occurs.

### 4.2.3 Overview of 3-Parameter Trim

The 3-parameter trim function can be enabled when the Mk8 EGA is used in conjunction with an MM module to manage the combustion. When the EGA detects any differences in the online exhaust gas readings to the original commissioned values, the trim function will make small corrections to the air damper (and channel 5 if optioned for trim), to bring those online values back to the commissioned readings. The trim function controls the combustion of the burner by adding air (air rich) or taking away air (fuel rich) from the commissioned air positions to keep the volume of O<sub>2</sub>, CO<sub>2</sub> and CO close to their commissioned values without compromising safety. The air rich and fuel rich limits are set by adding trim data when commissioning the burner or through single point change for 'quick commission.' This trim data is translated into a combustion map, which shows how the burner reacts when air is added or removed from the combustion process during commissioning. The Autoflame system continually monitors 3-parameters O<sub>2</sub>, CO<sub>2</sub> and CO to create the safest and most efficient way of trimming the combustion process.

Ingress of tramp air through an ill-fitting boiler or flue section will distort the O<sub>2</sub> reading and show an increase in this value. This results in the EGA reading the tramp air influence in the sample rather than just the actual combustion gases.

Single parameter O<sub>2</sub> trim systems would see both conditions as rich (excess air) combustion and start to trim back on the air by closing the air damper. In reality this trim process is not trimming the combustion gases at this point, but is in fact trimming the exhaust gases with the excess O<sub>2</sub>. This can potentially lead to the formation of excessive amounts of CO but more importantly this can lead to incomplete combustion with dangerous consequences.

Similarly, single parameter CO<sub>2</sub> trim systems would interpret of air as lower CO<sub>2</sub> levels in the flue, inflicting similar dangerous conditions in the boiler.

Another benefit of the 3-parameter trim is that the EGA is continually measuring the formation of CO compared to its commissioned value. A higher CO reading can be attributed to both lean and rich combustion. A lack of air will produce incomplete combustion and the formation of CO. Also, excess air around the flame envelope can chill the flame edge causing incomplete combustion and higher CO levels.

By referencing all 3-parameters against mapped combustion performance the burner can be trimmed back to the original commissioned values whilst maintaining the highest degree of safety.

When the trim function adds air to bring back the combustion to the commissioned values, as the burner modulates to a new position, the deviation in air damper movement is added to each air position. In this way, optimum combustion is maintained during modulation, through Carry-Forward Trim.

As a safety feature, as the air is being taken away, the fuel to air ratio will return back to the commissioned positions when the burner modulates, for every 10 degrees of fuel valve movement. Once this new position is held the system will determine whether the air damper should be closing. This always ensures safe combustion without any compromise.

## 4.3 EGA Trim Function

### 4.3.1 Trim Operation

With the EGA trim facility it is possible to expand the MM so it will measure and display O<sub>2</sub>, CO, CO<sub>2</sub> and exhaust gas temperature, together with boiler temperature or pressure. It is also possible to use these O<sub>2</sub>, CO and CO<sub>2</sub> values for 3-parameter trim in order to optimise the burner combustion throughout the firing range of the burner in a safe manner. This means that the safety is never compromised by efficiency, but the best burner/boiler efficiency is maintained. Correct set-up of the 3-parameter trim will maintain optimum combustion efficiency, whilst never compromising safety.

During commissioning, for every paired value of fuel and air, the corresponding values of O<sub>2</sub>, CO and CO<sub>2</sub> are stored. During the normal run mode, the on-line sample at any position within the burner's firing rate is compared to the commissioned values. There are 3 individually sampled parameters (O<sub>2</sub>, CO, CO<sub>2</sub>) in order to verify the combustion performance either side of the commissioned value. The software within the MM unit will apply minute corrections to the channel 2 air damper positions or the channel 5 variable speed drive in order to maintain the commissioned values. These small changes ensure that the originally entered commissioning data is adhered to, irrespective of variations in stack pressure, ambient temperature/pressure fluctuations, barometric conditions or fuel pressure changes.

The commission time is based on the residence time of the combustion gas. The residence time is measured by looking for a change in the O<sub>2</sub> reading from when the air damper is moved, to a change in combustion of >0.2% O<sub>2</sub>. This is the time from the moment the gas leaves the burner, to the moment it exits the boiler into the flue. This time will vary depending on how the burner is firing and the burner turn down ratios. This residence time is displayed in the combustion map screen. The residence time is typically longer at low fire than at high fire due to the volume of the gases passing through the boiler.

### 4.3.2 Importance of Measuring 3-Parameters

The Autoflame system trims on O<sub>2</sub>, CO<sub>2</sub> and CO, and so is not simply an O<sub>2</sub> trim system. If only O<sub>2</sub> is measured and trimmed on then there is no cross reference to CO, CO<sub>2</sub> or NO<sub>x</sub>. Therefore, even if the O<sub>2</sub> readings are correct, changes in ambient conditions can cause the CO to rise significantly (>>100ppm). Another, more dangerous problem that can occur is oxygen being induced into the boiler through gaskets and small gaps in the boiler flue ways. As the flue gas is measured at the exit of the boiler, this could lead to higher O<sub>2</sub> readings even if the combustion is good, i.e. high CO levels (>>100ppm), low O<sub>2</sub> levels. With a simple O<sub>2</sub> trim system, this potentially dangerous problem would not be accounted for. With the Autoflame EGA, O<sub>2</sub>, CO<sub>2</sub> and CO are constantly measured and any changes to these 3-parameters, will result in a trim taking place on the air damper to return the combustion level back to the original commissioned values. Therefore, even if both the O<sub>2</sub> and CO<sub>2</sub> are reading correctly the system will still trim due to changes in the amount of CO produced.

The following table shows a potential problem with using the O<sub>2</sub> analyser.

State	O <sub>2</sub> Analyser		3-Parameter Trim (Autoflame)			
	O <sub>2</sub>	CO	O <sub>2</sub>	CO <sub>2</sub>	CO	
1	3	0	3	10	0	Commissioned
2	4	0	4	10	0	Trim
3	4.5	100	4.5	10.5	100	Increased Trim
4	5	200	5	10.5	100	No trim
5	4	500	5.5	10	0	Commission position
6	3	1000+	5.5	10.5	50	Trim

Values in red are ones that are not viewable using an O<sub>2</sub> trim system.

State 1 – The burner is operating under normal conditions.

State 2 – Over a period of time, boilers are susceptible to leaks occurring. One of the most likely places that this will occur is on the stack, near to the point where the analyser is measuring the exhaust gases. As a leak occurs at this point, the analyser is not measuring solely the exhaust gases, but is in fact contaminated with 20.9% O<sub>2</sub> from atmosphere. Therefore, the oxygen reading starts to increase.

State 3 – As the amount of oxygen increases so too does the reading. At this point the controller closes the air damper in order to react to the increase in oxygen. The CO begins to rise since the combustion is now not correct.

State 4 – Both analysers still see an increase in the oxygen reading. The O<sub>2</sub> analyser continues to close the air damper in order to reduce the excess air through the system, and so producing CO. The Autoflame analyser measures the increasing CO value and ensures that the air damper does not continue to close.

State 5 – The O<sub>2</sub> analyser continues to trim based on the oxygen readings and so excess CO is produced. The Autoflame analyser has seen this ambiguous case and returns the air damper back to the commissioned value in order to ensure that the O<sub>2</sub>, CO<sub>2</sub> and CO levels are returned to the commissioned values (or close to) before further trimming occurs. This, potentially dangerous anomaly has been corrected for.

State 6 – Dangerous combustion occurs on the O<sub>2</sub> analyser, whereas the Autoflame EGA system has taken this ambiguous case into account.



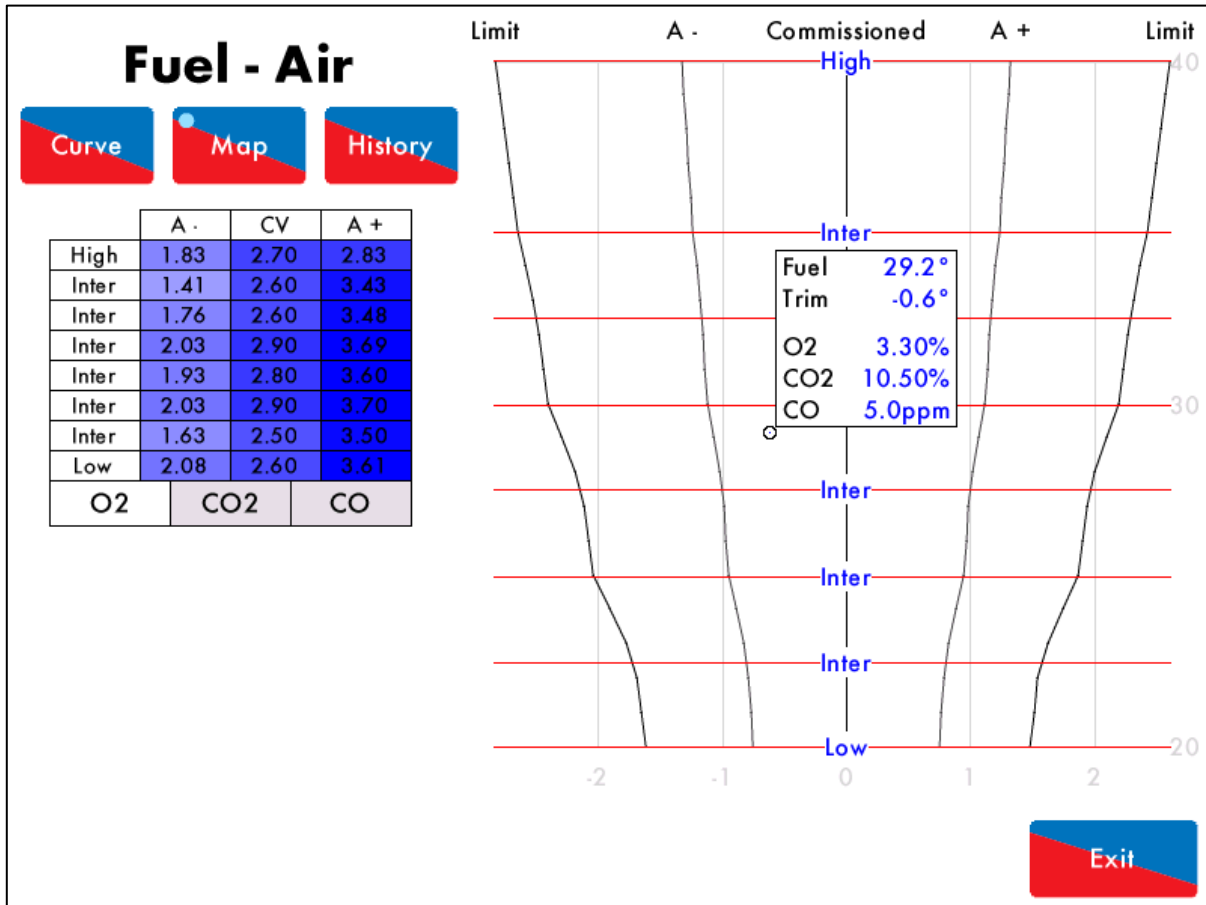

Figure 4.3.2.i Combustion Map Screen

The combustion map (see Figure 4.3.2.i) shows how the trim function works on the system. The combustion map screen can be accessed by pressing the ‘combustion map’ button on the M.M home screen. The combustion map clearly shows the commissioned EGA values for O<sub>2</sub>, CO<sub>2</sub> and CO. The graph on the right of the screen shows the amount of trim being added by the MM to control these emissions values so that they are as close to their commissioned values as possible. The small circle indicates the current position of the trim being applied and the current combustion values are displayed at this point as well.

### 4.3.3 Trim Correction Calculation

The additional correction calculated at each trim cycle is the combination of the correction determined for each of the combustion products O<sub>2</sub>, CO<sub>2</sub> and CO. The correction for each component is independently calculated. The calculation steps for each combustion product are as follows, “A-“ denotes Fuel-rich, “CV” denotes Commissioned Value, “A+” denotes Air-rich:

The commissioned values are calculated by interpolation for the current fuel valve position.

The current measured O<sub>2</sub> value is determined as air-rich or fuel-rich side of the commissioned value.

The adjustment which would give rise to the current reading is calculated by linear interpolation of the commissioned values.

Negate this adjustment to produce a correction.

The corrections for each product are then combined with additional weighting given to O<sub>2</sub> (x1.5) over CO<sub>2</sub> and CO (x1). This combined correction is then added to the running total correction and applied to the air channel. The total correction is limited by an option value set by default to ±10% for safety.

**Example**

The following shows an example calculation. At the current firing rate the interpolated commissioned values are:

	Fuel Rich (A-)	Commissioned Value (CV)	Air Rich (A+)
O <sub>2</sub>	2.8%	3.0%	3.4%
CO <sub>2</sub>	10.2%	10.0%	9.7%
CO	8ppm	5ppm	0ppm

The current measured values are:

	Measured
O <sub>2</sub>	3.5%
CO <sub>2</sub>	9.7%
CO	2ppm

Using linear interpolation the adjustments that would give rise to these concentrations are calculated:

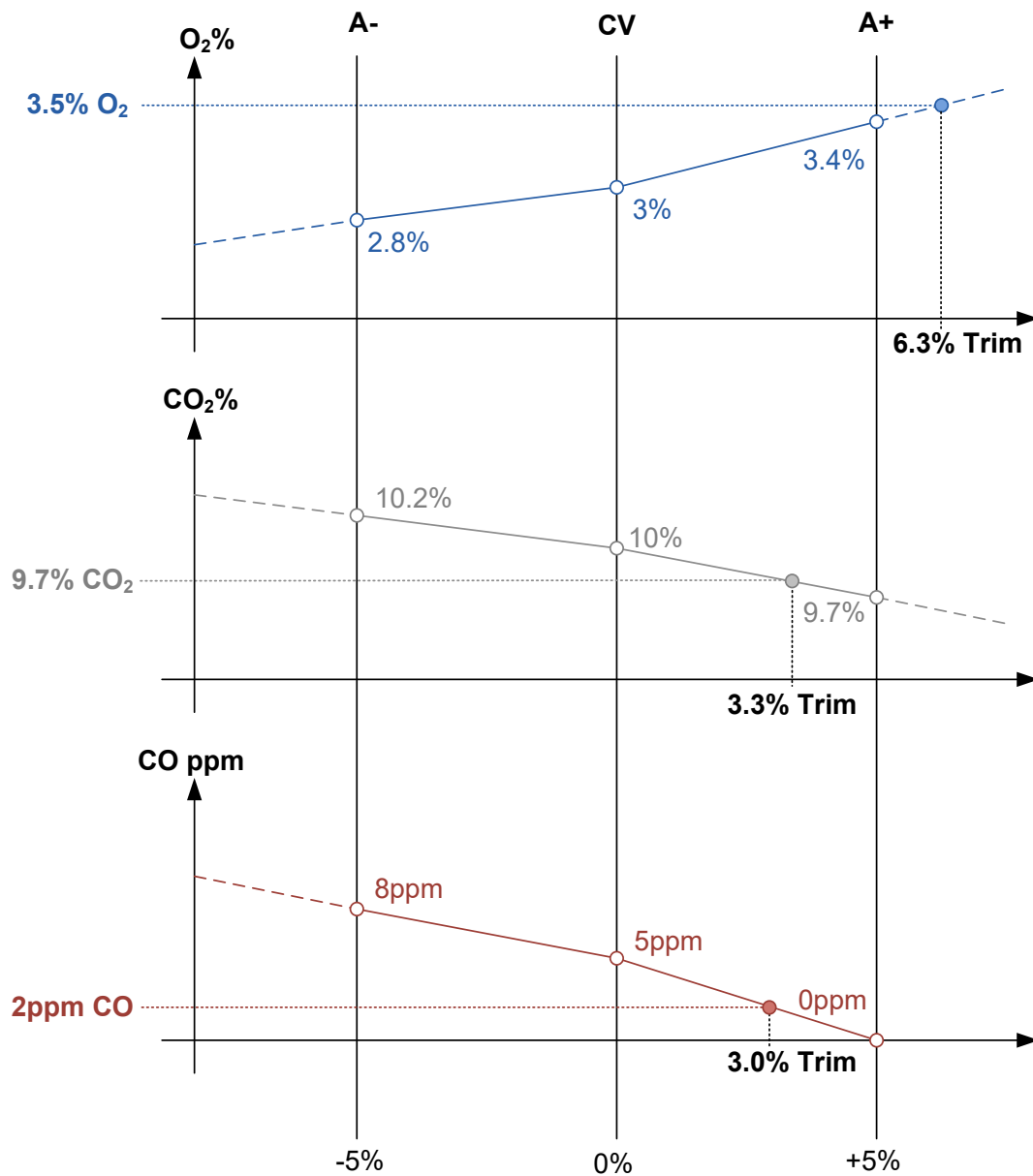

These are negated and combined using their respective weightings:

	Correction	Weighting	Weighted Correction
O <sub>2</sub>	-6.3%	1.5	-9.4%
CO <sub>2</sub>	-3.3%	1.0	-3.3%
CO	-3.0%	1.0	-3.0%
<b>Total</b>		3.5	-15.7%
<b>Average</b>			-4.5%

Giving an additional trim of -4.5%, which is then added to any existing trim; if for example, there was already +0.5% trim the resultant trim would be -4.0%. This trim fraction is then applied to the air channel, so if for example the air servo was at 52.0° a correction of -2.1° would be applied resulting in an air servo angle of 49.9°.

### 4.3.4 Trim Timing Operation

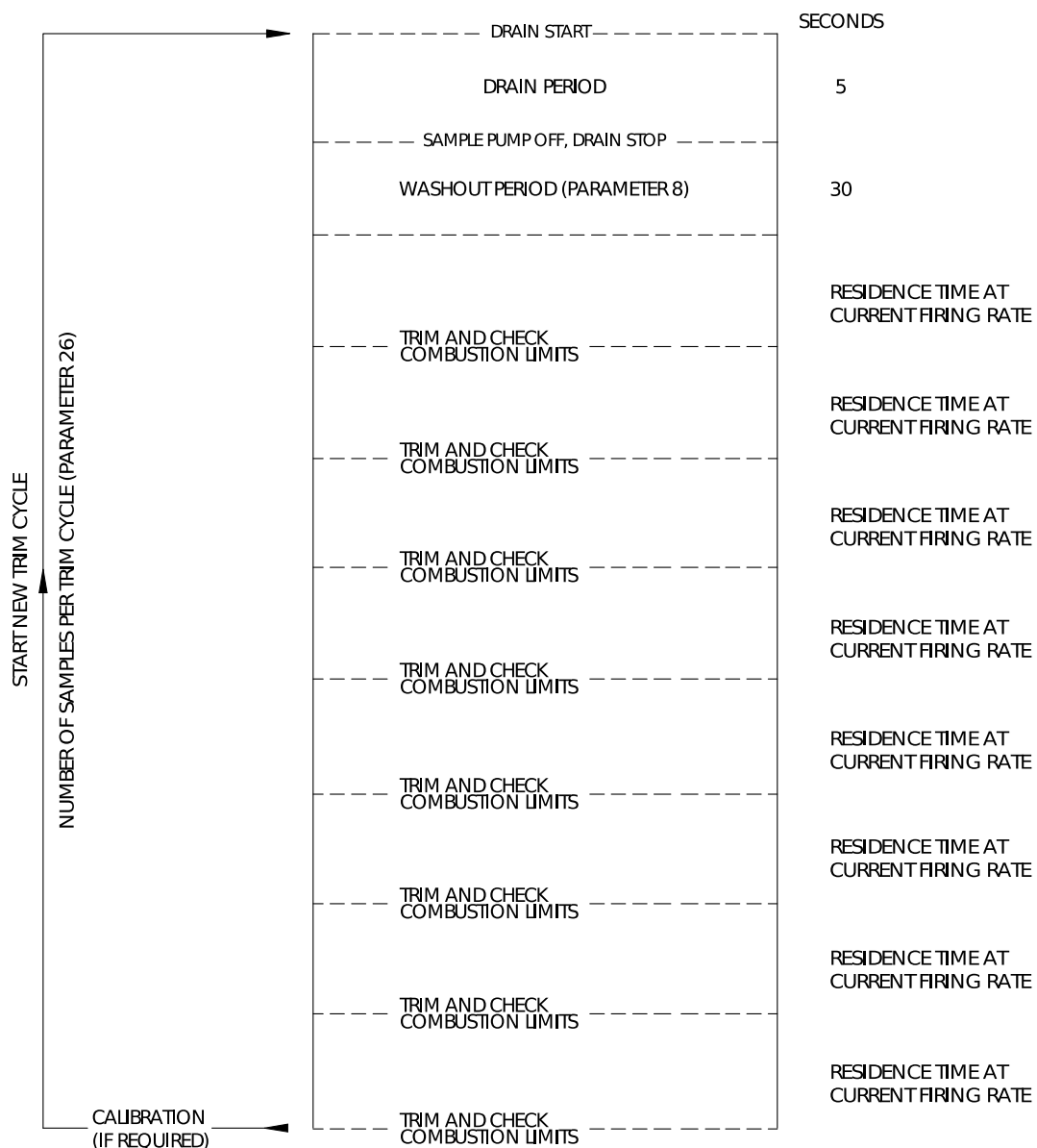

Figure 4.3.4.i Trim Timing Operation

If a calibration is due during the trim cycle, the MM will delay the calibration until the cycle has ended.

### **4.3.5 Channel 5 Trim (Mk8 MM Only)**

When trim is set on channel 5, changing the MM options will make a difference between errors occurring or not. For the purposes of trim, the Mk8 MM needs to know how the VSD will behave, in terms of a change in the VSD input and its effect on the feedback (output) signal, which is why the VSD Options (90 – 97) must be set exactly – i.e. input/output voltage/current ranges and input/output min/max Hertz. If the system is already commissioned and if any of the VSD drive input/output voltage/current ranges or input/output min/max Hertz are altered then re-commissioning will be necessary as the stored feedback values for each MM entered point will now be incorrect. These stored feedback values are used by the MM as the starting point for working out the expected feedback signal – whether trim on channel 5 is optioned or not.

### **4.3.6 Trim Delay**

On burner start-up without calibration the EGA performs a drain and starts sampling at 20.9% O<sub>2</sub> (fresh air), which then reduces to the commissioned value. Enough time must be given before the EGA commences trim, to ensure that it is not correcting the air damper at high O<sub>2</sub> values. The total time delay before the EGA starts to trim is based on the boiler's residence time. If the total time delay before trim starts is too short, then a scenario could arise where the EGA reads 5%O<sub>2</sub> and over-trims on air damper, reducing the O<sub>2</sub> too far.

If calibration on start-up is active, option 32 (trim delay) must be greater than the calibration time (parameter 24). A minimum of 40 seconds should be added. Parameter 24 is set as default to 120 seconds, so option 32 should be set to a minimum time of 160 seconds. The total time before trim is applied is 200 seconds (option 32 + parameter 8); this will also depend on the boiler's residence time.

## 4.4 Combustion Efficiency Calculations

Based on dry gas.

English Calculation:

*% Combustion Efficiency = 100 – (sensible heat loss + hydrogen and moisture loss)*

$$\%Combustion\ Efficiency = 100 - \left( \frac{K1(TG - TA)}{\%CO_2} + (K2(1121.4 + (TG - TA))) \right)$$

$K1 = 0.38$  Natural Gas (F1/F4)

$K1 = 0.56$  Fuel Oil (F2/F3)

$K2 = 0.0083$  Natural Gas (F1/F4)

$K2 = 0.0051$  Fuel Oil (F2/F3)

$TG$  Flue Gas Temperature

$TA$  Ambient Air Temperature in Boiler House

**Note:** To use these equations temperatures must be converted to °C.

European Calculation:

*%Combustion Efficiency = 100 – sensible heat loss*

$$\%Combustion\ Efficiency = 100 - \left( (TG - TA) \times \left( \frac{A}{20.9\% - O_2\%} + B \right) \right)$$

$A = 0.66$  Natural Gas (F1/F4)

$A = 0.68$  Fuel Oil (F2/F3)

$B = 0.009$  Natural Gas (F1/F4)

$B = 0.007$  Fuel Oil (F2/F3)

## 4.5 Combustion Limits

The combustion limits are only available when the EGA system is used in conjunction with a MM control module. The system will have improved safety from using the combustion limits, as these ensure that the combustion exhaust gases do not reach dangerous levels for health and safety, and also environmental regulations. The engineer can set limits as an offset value of the commissioned exhaust gases value, or as an absolute value. These can be upper or lower limits, depending on the exhaust gas variable and the application; the combustion limits can be set on 5 combustion variables: O<sub>2</sub>, CO<sub>2</sub>, CO, NO and exhaust gas temperature.

The limits of combustion can be adjusted through options 19 – 27 and parameters 94 – 97 on the MM module. Before the burner is commissioned, option 12 must be set correctly so that the limits of combustion are checked.

### Offset Limits

Standard (offset) limits are a set percentage volume above and below for O<sub>2</sub> and CO<sub>2</sub>, ppm above for CO and NO, and temperature above for exhaust gas temperature, for all the commissioned values. If the online exhaust gas values go above this offset of the commissioned value for that point in the firing curve, the burner will lockout or an error will be displayed, depending on how option 12 has been set on the MM. These values are entered after the commissioning of the EGA system has been completed throughout the firing range of the burner, according to health and safety requirements or environmental regulations.

### Absolute Limits

Absolute limits are a specific percentage volume, ppm or temperature. In this form only an ultimate low value may be put on O<sub>2</sub> and exhaust gas temperature in percentage volume and temperature respectively. In the case of CO<sub>2</sub> only an ultimate high value may be entered in percentage volume. For CO and NO an ultimate high in ppm may be entered. These values are entered when commissioning of the EGA system has been completed throughout the load index of the burner to avoid the burner locking out when commissioning.

### Combustion Limits Control Functions

Using Option 13 on the MM module it is possible to have two distinct control functions on how the system will react when the limits of combustion are exceeded.

#### Control Function 1

Once the combustion limits are exceeded the trim function is disabled automatically and the system runs on the fuel-air ratio positions that the MM module was commissioned on. An error will also appear on the MM module, and until the error is reset on the MM, the trim function will remain disabled, even if the combustion limits are no longer exceeded.

#### Control Function 2

Once the combustion limits are exceeded the MM module will lockout the burner. The MM module will also display an error message, and until the lockout is reset on the MM module, the system will remain in a lockout condition.

The following figures give a graphical presentation of how the standard limits of combustion works.

### 4.5.1 O<sub>2</sub> Combustion Limits

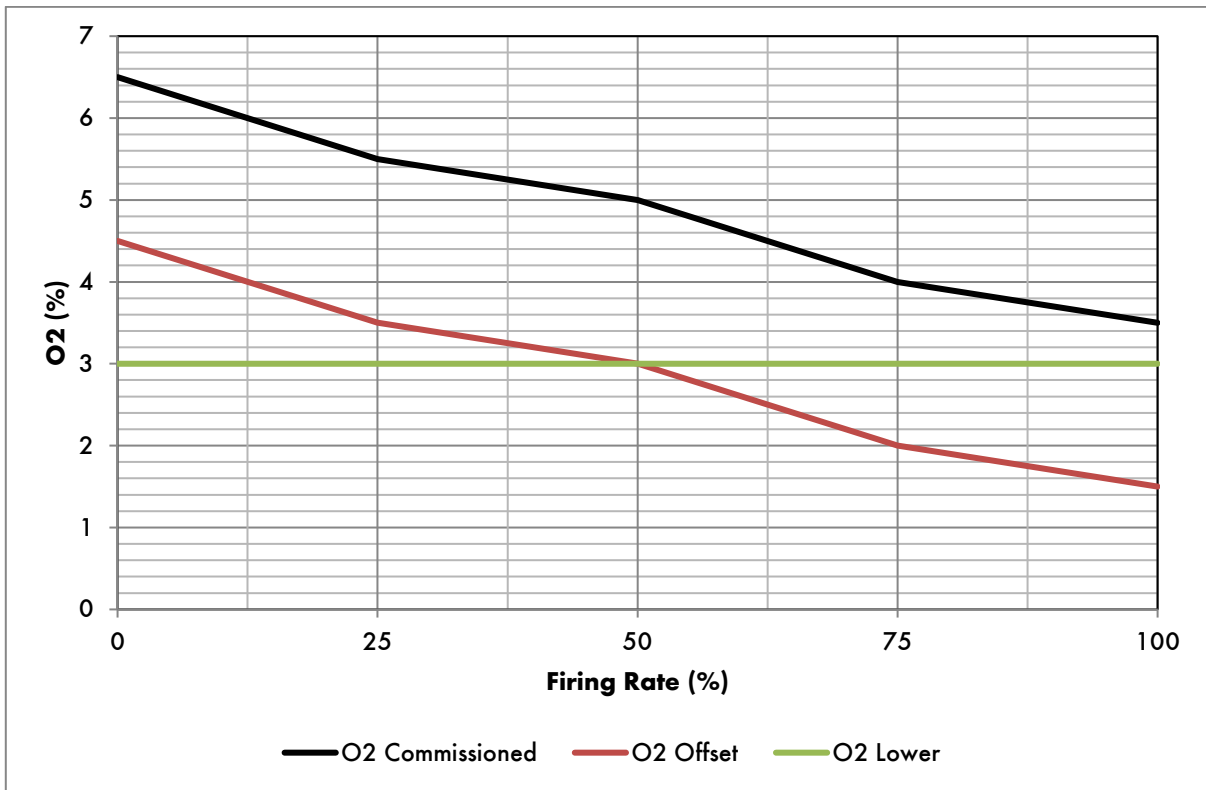

Figure 4.5.1.i O<sub>2</sub> limits example

Figure 4.5.1.i shows an example of the O<sub>2</sub> limits. If the offset limit was set to 2%, then the burner would alarm (depending on the terminal 79 operation) when the actual O<sub>2</sub> value dropped below 2% offset from the commissioned value. If the absolute lower limit was set to 3%, the burner would alarm when the actual O<sub>2</sub> value dropped below 3%.

### 4.5.2 NO Combustion Limits

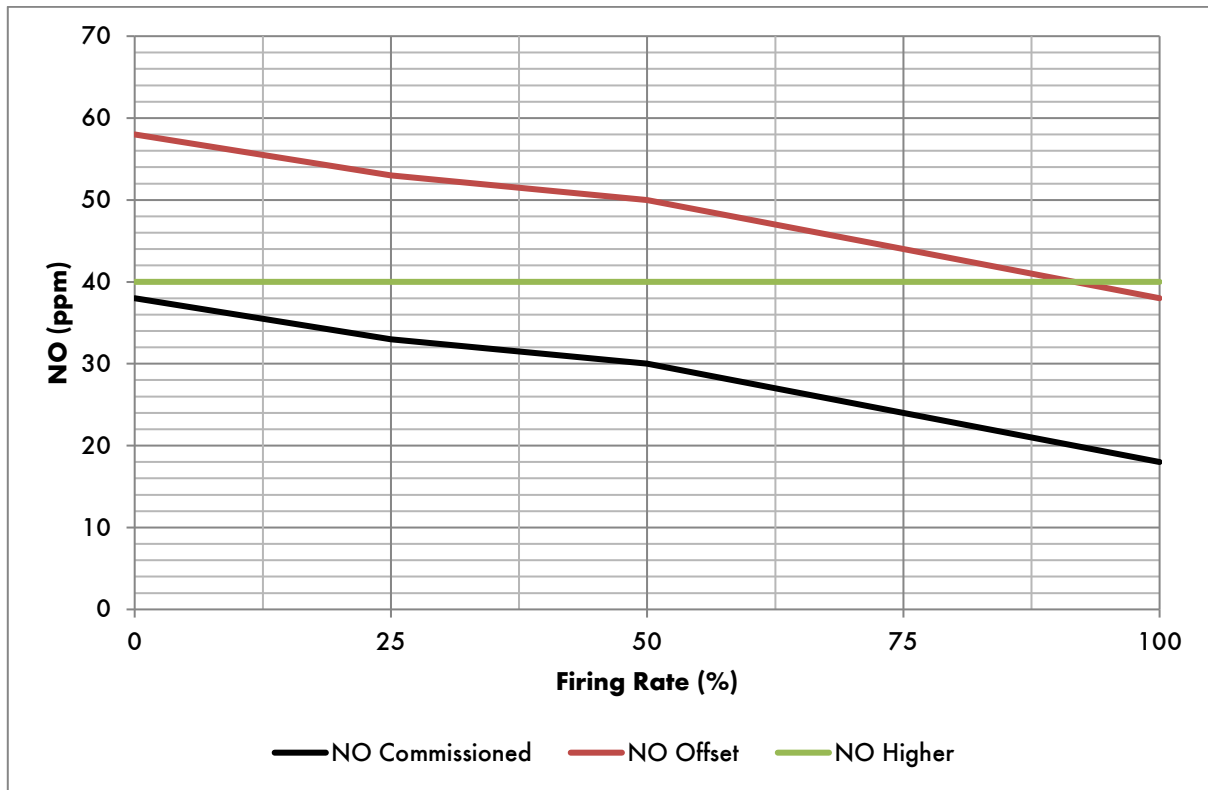

Figure 4.5.2.i NO limits example

Figure 4.5.2.i shows an example of the NO limits. If the offset limit was set to 20ppm, than the burner would alarm (depending on the terminal 79 operation) when the actual NO value rose above 20ppm offset from the commissioned value. If the absolute higher limit was set to 40ppm, the burner would alarm when the actual NO value rose above 40ppm.



### 4.5.3 CO Combustion Limits

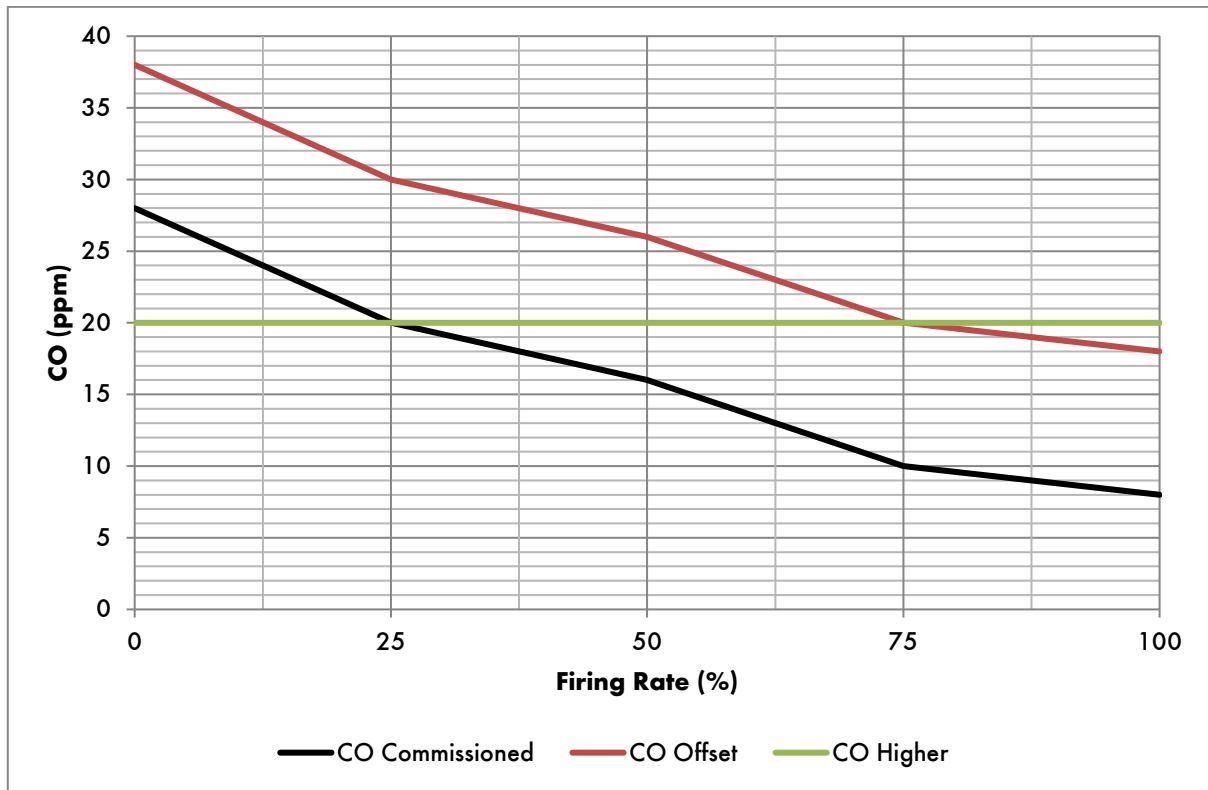

Figure 4.5.3.i CO limits example

Figure 4.5.3.i shows an example of the CO limits. If the offset limit was set to 20ppm, then the burner would alarm (depending on the terminal 79 operation) when the actual CO value rose above 20ppm offset from the commissioned value. If the absolute higher limit was set to 20ppm, the burner would alarm when the actual CO value rose above 20ppm.

### 4.5.4 Temperature Limits

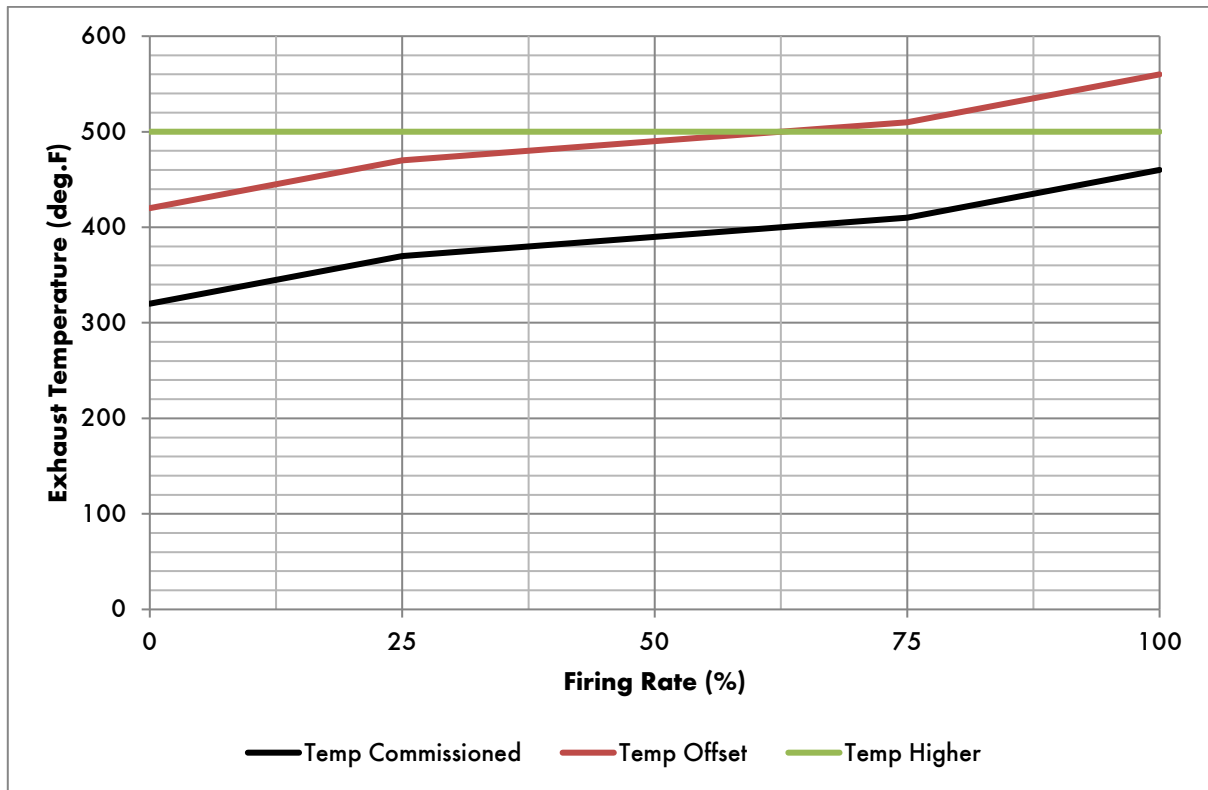

Figure 4.5.4.i Temperature limits example

Figure 4.5.4.i shows an example of the exhaust temperature limits. If the offset limit was set to 100°F, then the burner would alarm (depending on the terminal 79 operation) when the actual exhaust temperature value rose above 100°F offset from the commissioned value.

If the absolute higher limit was set to 500°F, the burner would alarm when the actual exhaust temperature value rose above 500°F.

## 4.6 Emission Gases Data Logging Units

The Mk8 EGA Evo logs gas concentrations for CO, NO, NO<sub>2</sub> and SO<sub>2</sub> in both PPM and mg/m<sup>3</sup>, so when the concentration unit is changed in EGA Setting 9, the graph on the EGA screen will display the emissions in the specified concentration unit.

The user has the option to download the long term EGA emissions data in either ppm or mg/m<sup>3</sup>. The preferred unit can be optioned first in Setting 9 (PPM and mg/m<sup>3</sup>) so that the downloaded long term emissions logs will have the same units as selected in Setting 9 before a download is taken.

The long term EGA data also includes the NO<sub>x</sub> concentration level (Combined NO and NO<sub>2</sub>).

## 4.7 Downloading EGA Long Term Logs

The EGA stores emissions and other data internally for a period of up to 3 years, these data can be downloaded from the EGA and exported into an Excel spreadsheet via IR lead using Autoflame Download Manager software. Please refer to the Autoflame PC Software Guide for full details.

On the Download Manger software, go to “Tools” and select “Download Long Term Logs”

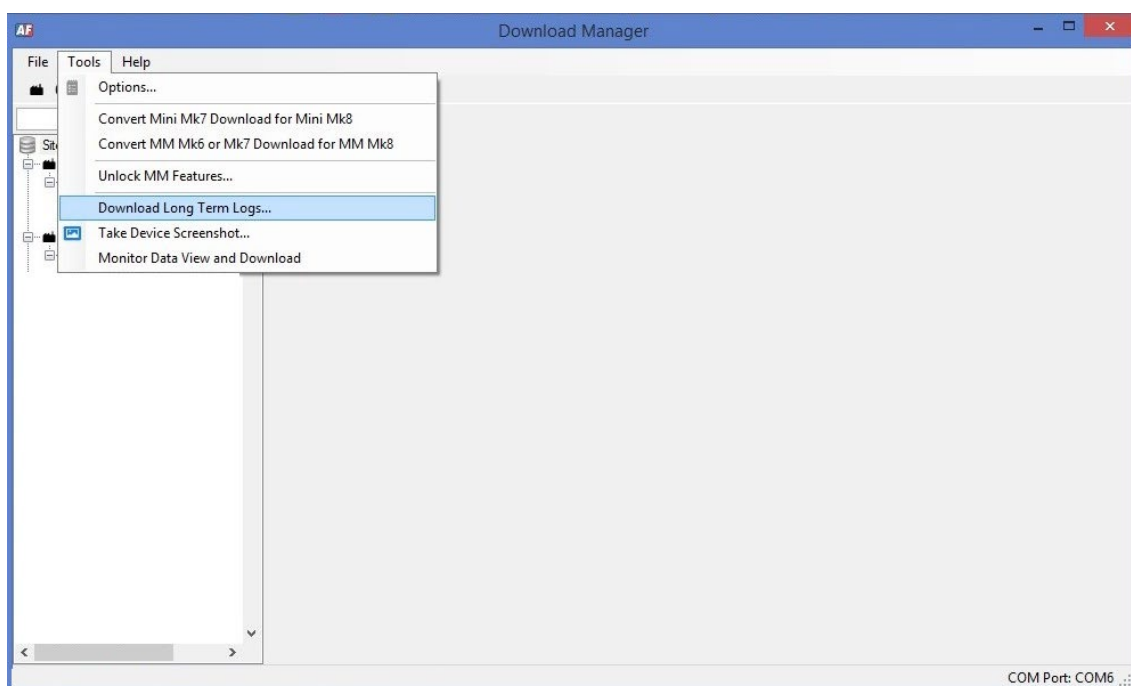

Figure 4.7 i: Autoflame Download Manager Software

On the newly opened “Download” window, select “Get Log Info”, the Download Manager will compile a list of downloadable EGA data.

Tick the boxes for any data that you want to download or click “All” to select all the data in the list. Click “Start” and the Download Manager will start downloading the data into your PC.

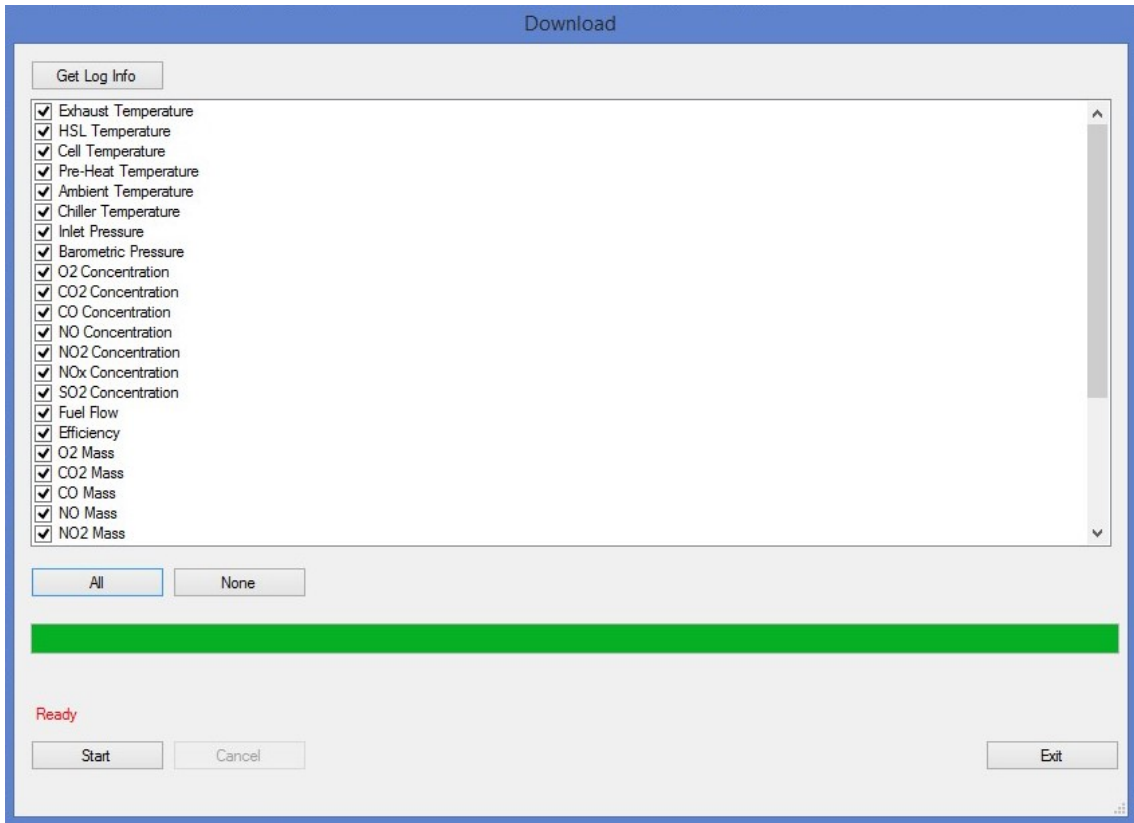

Figure 4.7 ii: selecting and downloading long term data from the EGA

## 5 REMOTE MONITORING

### 5.1 Overview

To access the EGA remotely for the purpose of monitoring, this can be done either by using a Mk8 DTI or by utilising the Direct Modbus feature available on the Mk8 EGA Evo. There are limited number of Modbus addresses available on the Mk8 EGA Evo which can be accessed directly without the need for a DTI.

Direct Modbus can be used if the EGA is set to Standalone (Setting 1 option 0). It is not possible to use Direct Modbus if the EGA is controlled by an MM (Setting 1 option 1). However in this case the Direct Modbus feature on the MM can be used to get the same live EGA values through the MM.

To access the EGA via DTI, please refer to the DTI setup guide for full details.

### 5.2 Wiring

The standard MM serial communication pins on the EGA flying lead are used for Direct Modbus for the EGA.

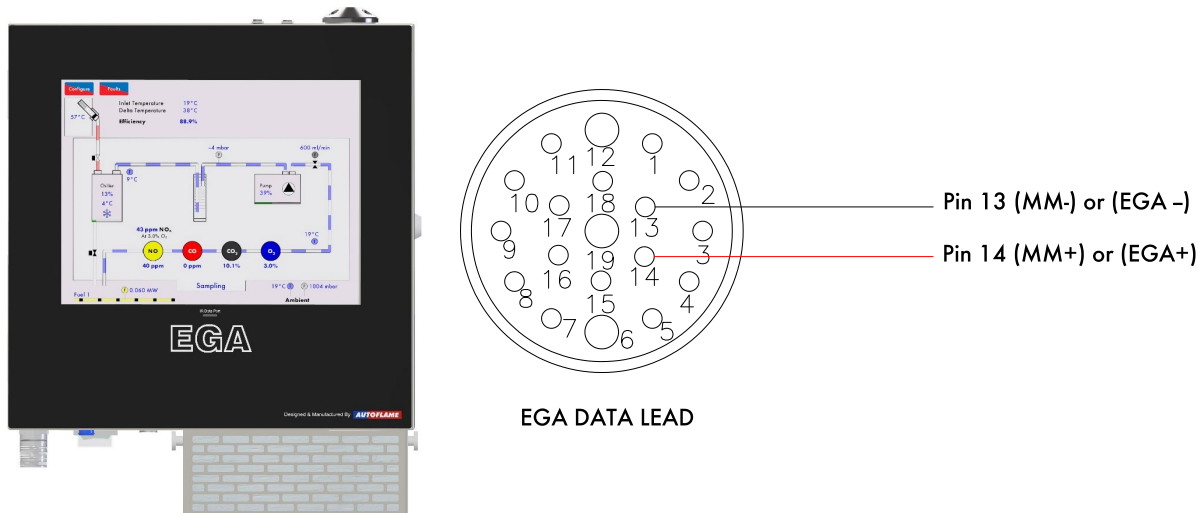

Figure 5.2 Direct Modbus connections on the EGA's flying lead

### 5.3 Direct Modbus Settings

The following EGA settings must be set to enable Direct Modbus to work correctly on the EGA:

Setting	Default	Range	Description
56	0	0 1	<u>Modbus Data Format</u> The Modbus data format on the EGA should be set the same as the baud rate used on the external Modbus communication program. Binary Format ASCII Format
57	1	1 – 247	<u>Modbus Device ID</u> This ID is used to recognise the device on the external Modbus communication program.
58	0	0 1	<u>Modbus Baud Rate</u> The baud rate on the EGA should be set the same as the baud rate used on the external Modbus communication program. 9600 Baud 19200 Baud
59	0	0 1 2	<u>Modbus Parity Setting</u> The parity on the EGA should be set the same as the baud rate used on the external Modbus communication program. No parity Odd parity Even parity

### 5.4 Modbus Addresses

There are 4 types of Modbus addresses:

0x Read/Write digital outputs – off/on commands

1x Read digital inputs – off/on signals/indications

These are binary values and have a 0/1 value indicating an off/on or no/yes value.

3x Read analogue inputs – variable data in

4x Read/Write analogue outputs – variable adjustments

These are multiple integer values and can have a value of 0 to 65534 and do not contain decimal points i.e. channel 1 position Modbus value is 900 which is equivalent to 90.0°

On the Mk8 EGA, the following addresses are available:

Digital (1x Read)

Address	Device	Description
10224	MM	EGA OK TO SAMPLE
10993	EGA	AIR CAL IN PROGRESS
10994	EGA	SELF CAL IN PROGRESS
10995	EGA	CHILLER READY
10996	EGA	AMBIENT TEMPERATURE OK
10997	EGA	AMBIENT TEMPERATURE HIGH
10998	EGA	AMBIENT TEMPERATURE LOW
10999	EGA	UNUSED 1
11000	EGA	EGA READY
11001	EGA	CO OPTIONED
11002	EGA	NO OPTIONED
11003	EGA	SO2 OPTIONED
11004	EGA	IMPERIAL UNITS
11005	EGA	IS SAMPLING
11006	EGA	PRE HEAT SENSOR ENABLED
11008	EGA	NO2 OPTIONED

Analogue (3x Read)

Address	Device	Description
30601	EGA	FUEL SELECTED
30602	EGA	O2 CONCENTRATION
30603	EGA	CO2 CONCENTRATION
30604	EGA	CO CONCENTRATION
30605	EGA	NO CONCENTRATION
30606	EGA	SO2 CONCENTRATION
30607	EGA	EXHAUST TEMPERATURE
30608	EGA	EFFICIENCY
30609	EGA	ERROR NUMBER
30611	EGA	DELTA TEMPERATURE
30612	EGA	AMBIENT TEMPERATURE
30613	EGA	PRE HEAT TEMPERATURE
30615	EGA	NO2 CONCENTRATION
30616	EGA	AMBIENT PRESSURE

## 6 SERVICING AND TROUBLESHOOTING

### 6.1 Servicing

The EGA is a sensitive instrument used to analyse the exhaust gases in the flue, so it needs to be serviced regularly to ensure accurate readings are taken for the trim function to maintain safe operation.

Due to the technology used within the Autoflame E.G.A, to ensure accurate and reliable operation the EGA requires annual servicing. Servicing the EGA and sampling probe is crucial to maintain the correct operation of the EGA and must be done regularly. For firing on natural gas, the EGA must be sent back every 12 to 18 months depending on the boiler room conditions. For firing on oil, this would be shortened to 6 to 12 months.

Failure to send back the EGA when it is due for a service will cause the operation and life of the EGA to deteriorate. The cells will need to be replaced as they are calibrated instruments which lose accuracy over time and use. The probe is constantly sampling the gases and can become easily clogged with debris and dirt picked up from the burner, without a service this can result in incorrect readings which affect the reliability of the EGA. Further issues such as pump problems, chiller faults and inaccurate trim operation will occur.

#### 6.1.1 Sampling Probe Maintenance

On gas only applications it is unlikely that there should be continual maintenance required on the stack mounted probe. It is advised that the probe is checked annually on the gas firing applications in order to ensure that the probe is free of any blockages. On heavy or solid fuel applications, deposits may build up in the outlet part of the tube, causing EGA faults.

The deposits can be cleared by running a long drill (7mm/0.275") up into the outlet tube by hand. Twist and withdraw the drill often to pull out the deposits, otherwise the deposits will be pushed further into the probe assembly.



Figure 6.1.1.i Method of Cleaning a Blocked Outlet Tube



### 6.1.2 Servicing EGA Sampling Probe

If the filter assembly in the EGA sampling probe is blocked then it is necessary to disassemble the probe and fit a new pre-formed fine filter and coarse filter. To check if the probe is blocked connect the probe to the EGA and allow the EGA to sample. If the pump pressure or flow rate drops below 550 ml/min respectively then the filtering material should be replaced.

1. To disassemble the probe, unscrew the casing from the base of the probe. See diagram in section 1.5.1. The whole of the internal assembly can now be withdrawn from the sample connection end.
2. Remove the sampling tube and thermocouple from the EGA and unscrew the end cap.
3. Retract the filter and thermocouple from inside the probe at the same angle.
4. Replace the filter on the end of the thermocouple; the thermocouple can also be replaced.
5. Loose the 2mm set screw located above the cap extract the thermocouple.
6. Replace the thermocouple and retighten the set screw.
7. Remove all traces of the filtering materials from the stainless steel filter.
8. Check that the stainless steel filter and inner sample tube are clear inside.
9. Very carefully push the delicate pre-formed filter onto the stainless steel filter.
10. Slide the inner assembly back into the stainless steel outer casing.
11. Pack the void between the fine filter and the outer casing with coarse filtering material.
12. Use a small rod to pack the material down a little at a time.
13. Reassemble by sliding the assembly into the casing and screw together.

After reassembly connect the probe to the EGA and check the pump pressure and flow.

## **6.2 Shipping**

The EGA is a scientific instrument with delicate components. Whenever the EGA is shipped it is essential that the EGA is returned using its original packaging.

Ensure that couriers treat the package appropriately and label it as containing a delicate scientific instrument. If the EGA is damaged in transit, repair costs will be incurred.

Please contact Autoflame or your local Tech Centre to obtain new Autoflame EGA packaging.

### 6.3 Fault Codes

There are two types of faults on the EGA, errors and warnings. Errors stop the EGA from sampling, and Warnings do not stop the EGA from sampling. If the EGA is connected to an MM, option 13 will set where the MM turns the burner off or continues running when an EGA fault occurs.

Please refer to the MM Installation and Commission Guides for EGA fault codes displayed on the MM.

**Note:** The EGA will display the fault message relevant to the component, e.g. if the fault code 0 will display as 'CO Cell Invalid' on the EGA fault screen, for a CO cell fault.

Fault	Message	Type
0	Cell Invalid	Error
	<ul style="list-style-type: none"> <li>The displayed cell is either not detected or the incorrect type has been fitted on start-up (O<sub>2</sub>, NO, CO, CO<sub>2</sub>, NO<sub>2</sub>, SO<sub>2</sub>).</li> <li>Check the cell has been installed correctly.</li> </ul>	
1	Cell Data Loaded	Warning
	<ul style="list-style-type: none"> <li>A new displayed cell has been detected and calibration data has been reloaded.</li> <li>This is the correct response to a new cell being fitted.</li> </ul>	
2	Blocked Input	Error
	<ul style="list-style-type: none"> <li>Input pressure below optioned fault threshold.</li> <li>Check Commission Mode setting 47.</li> <li>Check the air inlet filter, and the external particulate filter, if fitted.</li> </ul>	
3	Blocked Output	Error
	<ul style="list-style-type: none"> <li>Barometric pressure is above optioned fault threshold.</li> <li>Check Commission setting 48.</li> </ul>	
5	Ambient Temperature Low	Warning
	<ul style="list-style-type: none"> <li>Ambient temperature is below 3°C (37.4°F)</li> </ul>	
6	Ambient Temperature High	Warning
	<ul style="list-style-type: none"> <li>Ambient temperature is above 42°C (107.6°F)</li> </ul>	
7	Chiller Frozen	Error
	<ul style="list-style-type: none"> <li>Chiller temperature is below 0°C</li> <li>Chiller will then shut down to warm up, if the temperature goes above this low limit of 0°C, the fault will automatically clear and the EGA will resume normal operation.</li> </ul>	
8	Chiller Temperature High	Warning
	<ul style="list-style-type: none"> <li>Chiller is not cooling</li> </ul>	
10	Flow Out of Range	Error or Warning
	<ul style="list-style-type: none"> <li>Sample flow rate is less than 500ml/min or more than 700ml/min</li> <li>For the main pump in a standard EGA, this fault is an error. For the self-calibration pump in a self-calibration EGA, this is a Warning.</li> </ul>	
11	Self-Cal Low Pressure	Warning
	<ul style="list-style-type: none"> <li>Self-calibration has failed due to low source gas pressure.</li> <li>Check the indicated gas supply, this fault could mean there is no gas in the bottle.</li> </ul>	
12	Self-Cal High Pressure	Warning
	<ul style="list-style-type: none"> <li>Self-calibration failed due to high source gas pressure.</li> <li>Check the pressure regulator for the gas supply.</li> </ul>	
13	HSL Out of Range	Warning
	<ul style="list-style-type: none"> <li>Heated Sample (HSL) temperature is out range.</li> <li>Check the HSL supply fuse and check the connections</li> </ul>	

<b>Fault</b>	<b>Message</b>	<b>Type</b>
14	Excess Calibration Drift	Error
	<ul style="list-style-type: none"> <li>• Calibration drift is out of range.</li> <li>• Check Commission Mode Settings 23 to 26.</li> </ul>	
15	Temperature Sensor	Error or Warning
	<ul style="list-style-type: none"> <li>• The displayed temperature sensor is faulty.</li> <li>• Check the connections on the thermocouple and the pre-heated air sensor</li> </ul>	
16	Pressure Sensor	Error
	<ul style="list-style-type: none"> <li>• The displayed pressure sensor is faulty.</li> <li>• Please contact Autoflame or local approved Autoflame tech centre.</li> </ul>	
17	Chemical Sensor	Error
	<ul style="list-style-type: none"> <li>• The displayed chemical cell is faulty, check the connections.</li> </ul>	
18	Optical Sensor	Error
	<ul style="list-style-type: none"> <li>• CO<sub>2</sub> cell is faulty, check the connections.</li> </ul>	
19	Optical Bulb	Warning
	<ul style="list-style-type: none"> <li>• CO<sub>2</sub> cell bulb current is below 50mA.</li> <li>• Check the connections.</li> </ul>	
20	Fan Blocked	Warning
	<ul style="list-style-type: none"> <li>• Ventilation fan frequency is below 40Hz.</li> <li>• Check the air inlet filter.</li> </ul>	
21	EEPROM Write Failed	Error
	<ul style="list-style-type: none"> <li>• EEPROM data could not be written after multiple attempts.</li> </ul>	
22	EEPROM Read Failed	Error
	<ul style="list-style-type: none"> <li>• EEPROM data could not be read after multiple attempts.</li> </ul>	
23	Clock Not Set	Warning
	<ul style="list-style-type: none"> <li>• Clock not set.</li> <li>• Check the battery on the main PCB.</li> </ul>	
24	Service Interval	Error or Warning
	<ul style="list-style-type: none"> <li>• Service interval has expired.</li> <li>• Check Commission Mode setting 54 for service interval and 55 for service interval error period.</li> </ul>	
25	Calibration Result Invalid	Warning
	<ul style="list-style-type: none"> <li>• A cell calibration is rejected.</li> <li>• Check gas bottles are in correct port.</li> </ul>	
26	Software Error	Warning
	<ul style="list-style-type: none"> <li>• Please contact Autoflame or local approved Autoflame tech centre.</li> </ul>	
27	Software Error	Error
	<ul style="list-style-type: none"> <li>• Check the software versions installed in the EGA are compatible.</li> <li>• Please contact Autoflame or local approved Autoflame tech centre.</li> </ul>	
28	Software Error	Error
	<ul style="list-style-type: none"> <li>• Software is corrupt, re-install EB software.</li> <li>• Please contact Autoflame or local approved Autoflame tech centre.</li> </ul>	
29	Software Error	Warning
	<ul style="list-style-type: none"> <li>• Please contact Autoflame or local approved Autoflame tech centre.</li> </ul>	
30	Display Communications	Error
	<ul style="list-style-type: none"> <li>• Check connections between display PCB and main PCB.</li> <li>• Please contact Autoflame or local approved Autoflame tech centre.</li> </ul>	
31	Display Log Write Fail	Error
	<ul style="list-style-type: none"> <li>• Unable to write CEMS data to the SD card, check the SD card.</li> </ul>	

### 6.3.1 General Troubleshooting

- Ambient Temperature – This must be between 5 – 40°C (40 – 140°F). The temperature is measured by a sensor on the electronics PCB and is cross referenced with the sensor on the side of the CO<sub>2</sub> cell.
- Chiller – This will be Ready or Not Ready. There is a temperature sensor on the chiller unit and this chiller must get down to a set temperature before the pump will start to draw a sample from the stack. If the chiller is not decreasing its temperature then check the operation of the fan. If the ambient air in the boiler house is high, it may be necessary to draw cooler air into the EGA. In warm environments, an air conditioned enclosure should be used; in cold environments a heated enclosure should be used.
- If the EGA is mounted in an excessively dusty environment a build-up of particles on the terminals can cause arcing. If the particles are corrosive then any attack to the conformal coating on the printed circuit boards can cause tracks to arc and component failure. Any sign of this activity and the unit should be returned to the supplier.
- If you get a continuous O<sub>2</sub> reading of 20%, this tells you that the Mk8 EGA is sampling fresh air. To troubleshoot this:
  - a. Check all piping is airtight
  - b. Check sample tube is not blocked
  - c. Check that there are no leaks on the flue
  - d. Check the pinch valve tubing for leaks

### 6.3.2 Faults on MM

In the event of an EGA failure, an error will appear on the EGA screen of the MM. The MM will show 'See EGA for fault description.' All other screens on the MM are still viewable whilst there is an EGA error. The switched neutral alarm output Terminal 79 can be set to become active or remain inactive in the event of an EGA error (see Option 12). The setting of Option 12 will determine how the burner will operate, i.e. continue to run based on the original commissioned values (trim and limits testing disabled) or lockout the burner until the EGA error is reset and becomes fully operational once again.

It is possible to remove and re-install the EGA at a later date without the burner needing to be re-commissioning if using the trim function with an MM module. After removing the EGA set Option 12 on the MM module to 0. Once the EGA module is ready to be re-installed reset Option 12 back to the required setting, provided the combustion has not been changed either through commissioning mode or single point change the MM module will load up as normal and will not be required to be re-commissioned.

When an error code appears on an MM module it is required that the error is reset on the MM module as well as the EGA. If the error is not reset on the MM, the EGA and MM will not communicate with each other. This will mean the EGA will display "No Fuel Selected" when in run with MM mode until the error is reset.

When first going into commissioning mode, the MM invokes an EGA calibration. If an error occurs at this stage it will be necessary to investigate and resolve the error before restarting the commissioning procedure.

The table below shows the EGA errors on the MM. Option 13 sets the way the MM responds to an EGA error.

<b>EGA Error</b>	<b>Description</b>
1	EGA Internal Error Check EGA for fault.
2	No Communications Check parameter 10 is set to correct EGA version. Check EGA operating mode is selected as 'EGA with MM.' Check wiring between EGA and MM (terminals 25 and 26 on MM).
3	O <sub>2</sub> Upper Limit Current O <sub>2</sub> value is above upper offset limit of commissioned value.* Check exhaust gas readings and option 19.
4	O <sub>2</sub> Absolute Limit Current O <sub>2</sub> value is below absolute limit.* Check exhaust gas readings and option 25.
5	O <sub>2</sub> Lower Limit Current O <sub>2</sub> value is below lower offset limit of commissioned value.* Check exhaust gas readings and option 22.
6	CO <sub>2</sub> Upper Limit Current CO <sub>2</sub> value is above upper offset limit of commissioned value.* Check exhaust gas readings and option 20.
7	CO <sub>2</sub> Absolute Limit Current CO <sub>2</sub> value is above absolute limit.* Check exhaust gas readings and option 26.
8	CO <sub>2</sub> Lower Limit Current CO <sub>2</sub> value is below lower offset limit of commissioned value.* Check exhaust gas readings and option 23.
9	CO Upper Limit Current CO value is above upper offset limit of commissioned value.* Check exhaust gas readings and option 21.
10	CO Absolute Limit Current CO value is above absolute limit.* Check exhaust gas readings and option 27.
11	NO Upper Limit Current NO value is above upper offset limit of commissioned value.* Check exhaust gas readings and parameter 94.
12	Exhaust Temperature Upper Limit Current exhaust temperature is above upper offset limit of commissioned value.* Check exhaust gas readings and parameter 96.
13	Exhaust Temperature Absolute Limit Current exhaust temperature is above absolute limit.* Check exhaust gas readings and parameter 97.

\*When option 12 is set to 3 for trim and combustion limits, the combustion limits are evaluated once per trim cycle. A combustion limit error will occur if the current exhaust value has crossed the combustion limit for the number of trim cycles set in parameter 17 (the default value is 3 cycles).

**Technical Manual**  
**Mk8 EGA EVO**  
**Part#. MM82004/E**  
**4 December 2019**

AUTOFLAME ENGINEERING LTD  
Unit 1-2, Concorde Business Centre  
Airport Industrial Estate, Wireless Road  
Biggin Hill, Kent TN16 3YN  
United Kingdom

Tel: +44 (0)1959 578 820  
Email: [technicalsupport@autoflame.com](mailto:technicalsupport@autoflame.com)  
Website: [www.autoflame.com](http://www.autoflame.com)

